

J&W Electronics Co.,LTD

Board name: Mother Board Schematic
Project name: C116
Version: VerA
initial Date: 2011-03-13
New update:

1. System Block Diagram & Schematic page description;
2. Power Block Diagram & Discription;
3. Annotations & information;
4. Schematic modify Item and history;
5. Power on & off Sequence;
6. ACPI Mode Switch Timings;
7. Power On Sequence Map;
8. CLOCK Distribution;
9. Power Distribution;

J&W Confidential

Hardware drawing by:

Hardware check by:

EMI Check by:

Power drawing by:

Power check by:

Manager Sign by:

Title			
<Title>			
Size	Document	Number	Rev
Custom	WANGQ		<Rev>
Date:	Saturday, January 11, 2014		Sheet 1 of 28

POWER SEQUENCE

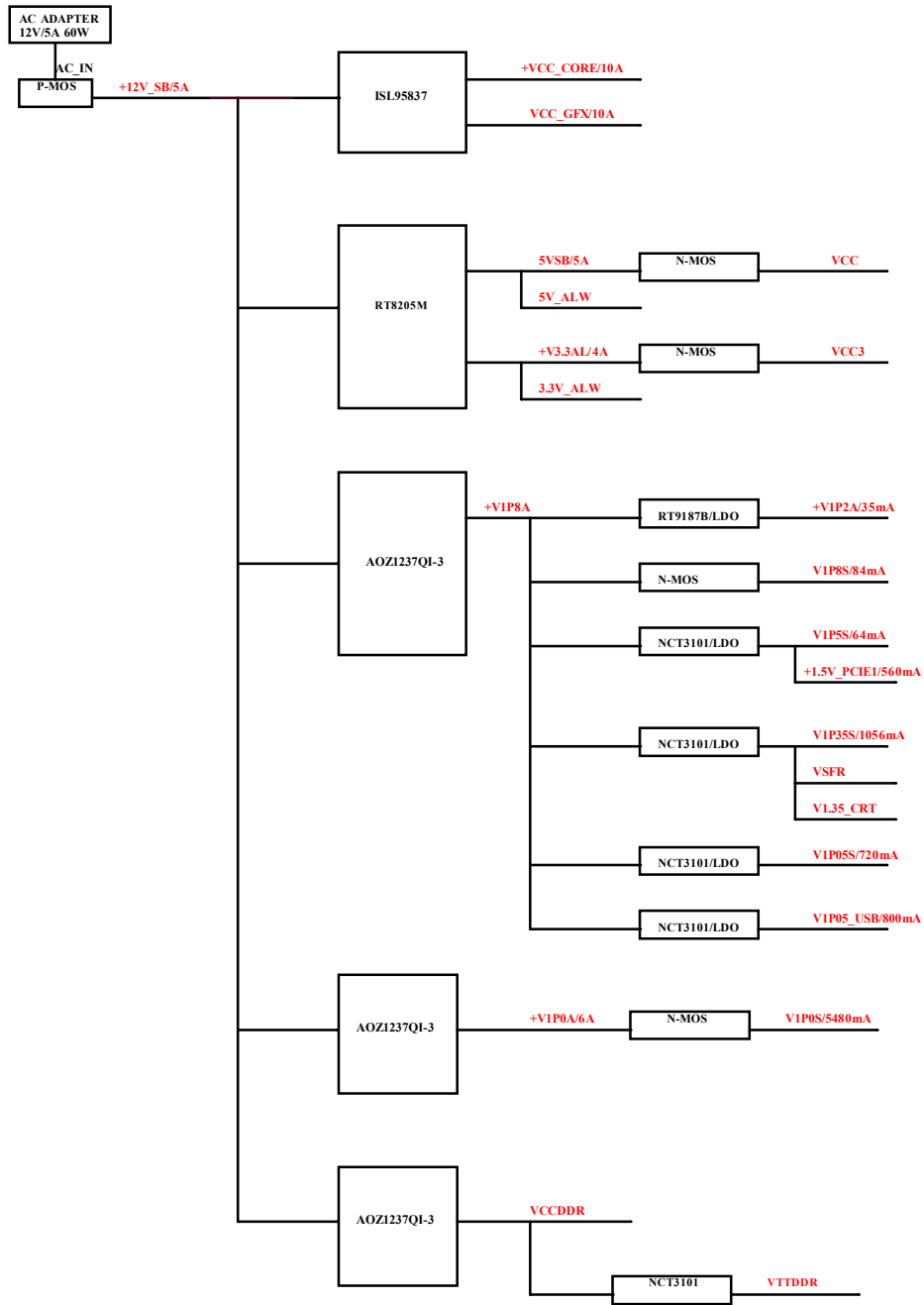

Title			
POWER RAIL			
Size	Document Number	Rev	
Cust	WANGCO	1	Rev
Date:	Saturday, January 11, 2014	Sheet	2 of 28

>>>M0_DQSP[7:0] 8
 >>>M0_DQSN[7:0] 8
 >>>M0_DQ[63:0] 8
 >>>M0_MA[15:0] 8
 >>>M0_DM[7:0] 8

>>>M1_DQSP[7:0] 8
 >>>M1_DQSN[7:0] 8
 >>>M1_DQ[63:0] 8
 >>>M1_MA[15:0] 8
 >>>M1_DM[7:0] 8

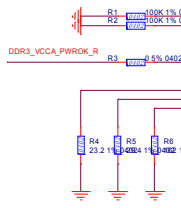
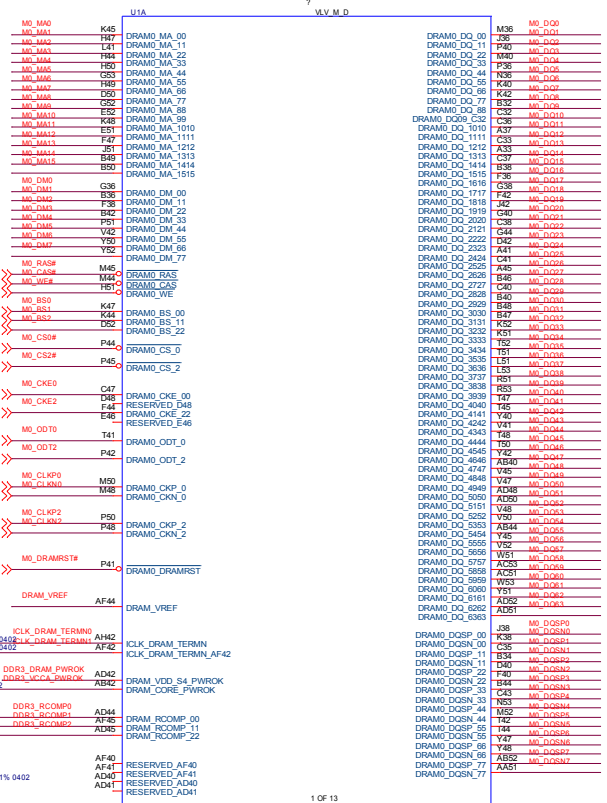

CLOSE SOC

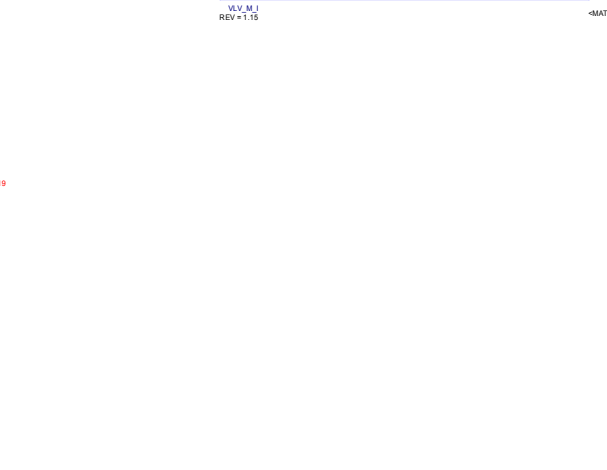
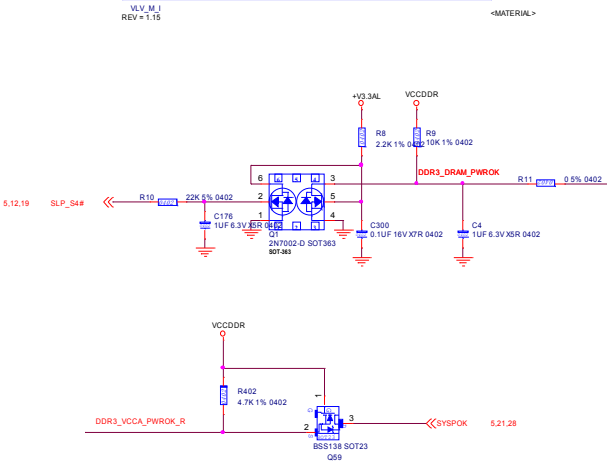

File	SOC DDR		
Size	Document Number	WANG	Rev
Date:	Saturday, January 11, 2014	Sheet	3 of 28

HDMI

DP

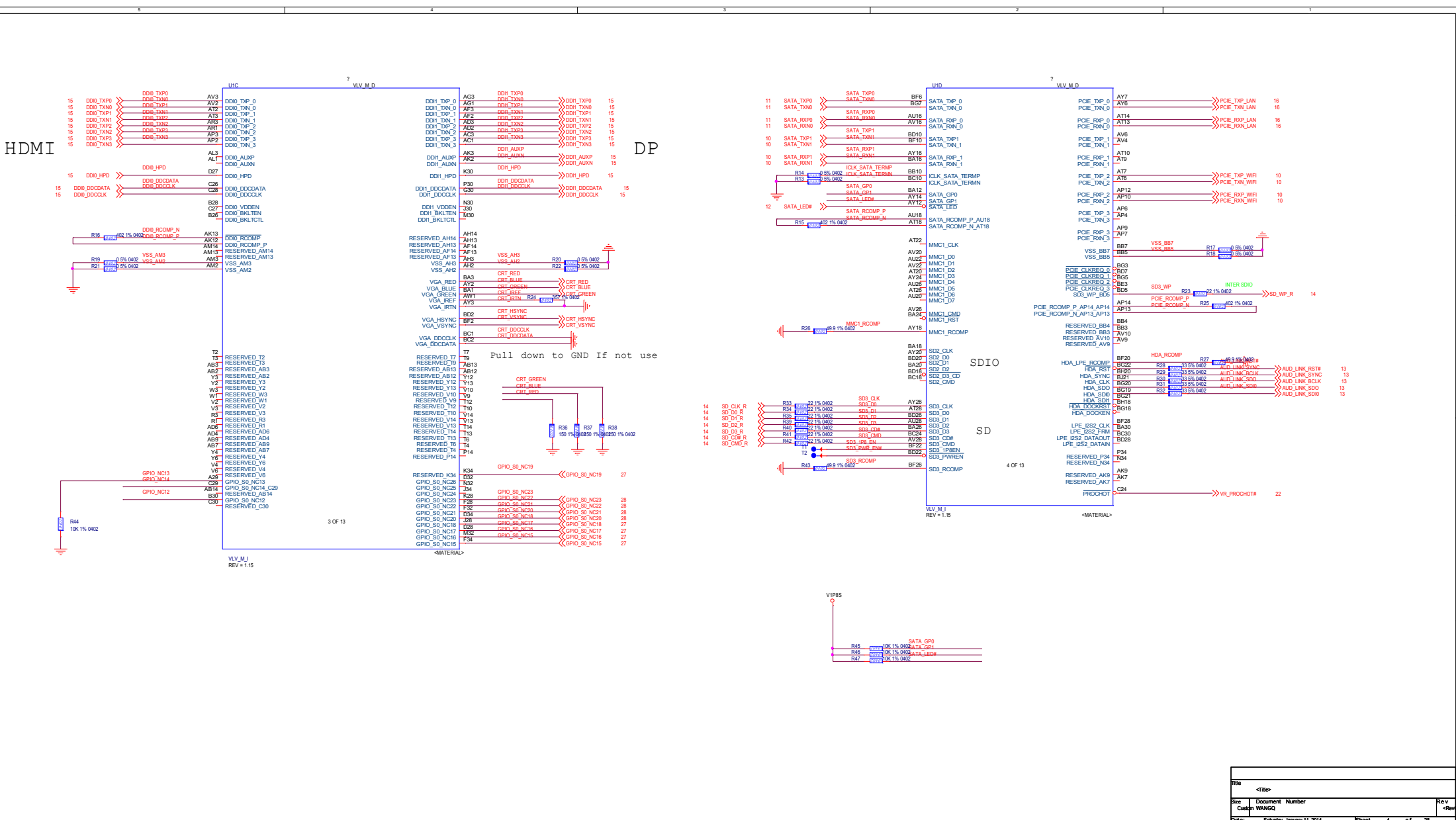

Title	<Title>
Doc. No.	Document Number
Date	2014.01.11
Sheet	4 of 28

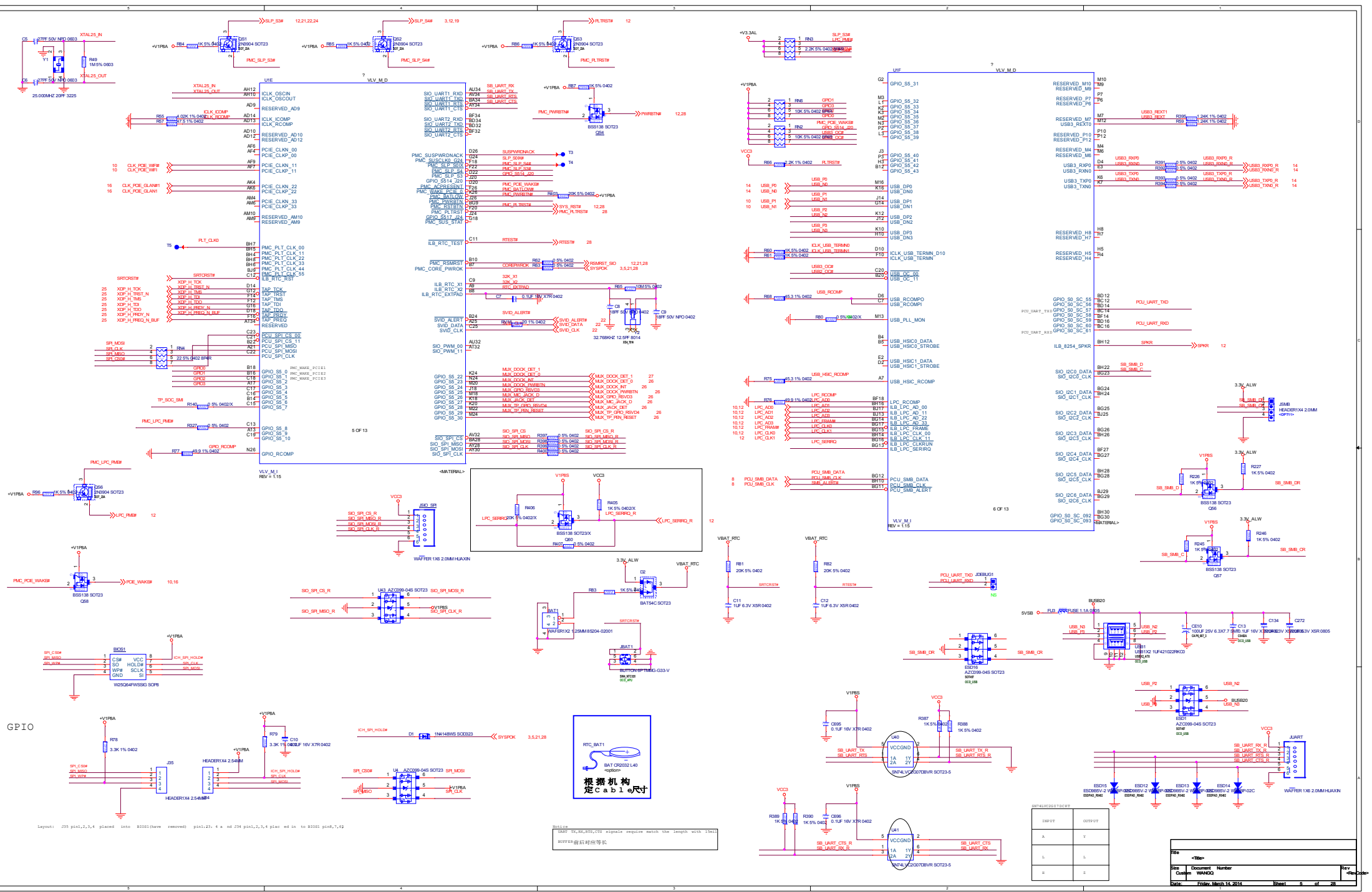

Layout: 238 pin1,2,3,4 placed into B001(these removed) pin1,2, 4 + net 234 pin1,2,3,4 placed in to B001 pin1,7,2

根据机构定c a b l e尺寸

011110 12,16,20,24,28 signals require match the length with 15ohm
SMT07 前后对称等长

INPUT	OUTPUT
A	Y
L	L
S	S

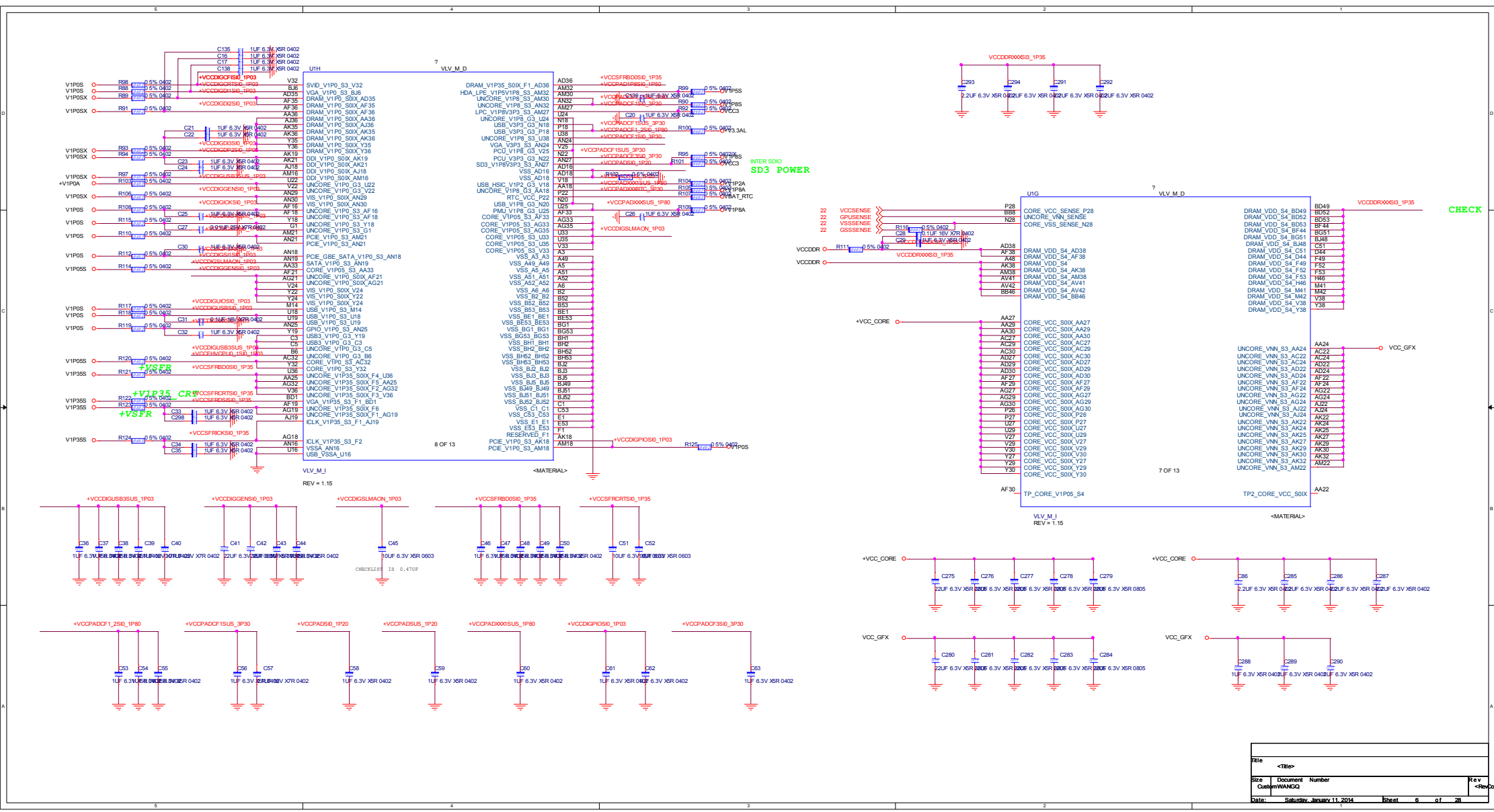

File	Document	Number	Rev
<Title>	Custom	WANGQ	
Date:	Saturday, January 11, 2014	Sheet	6 of 28

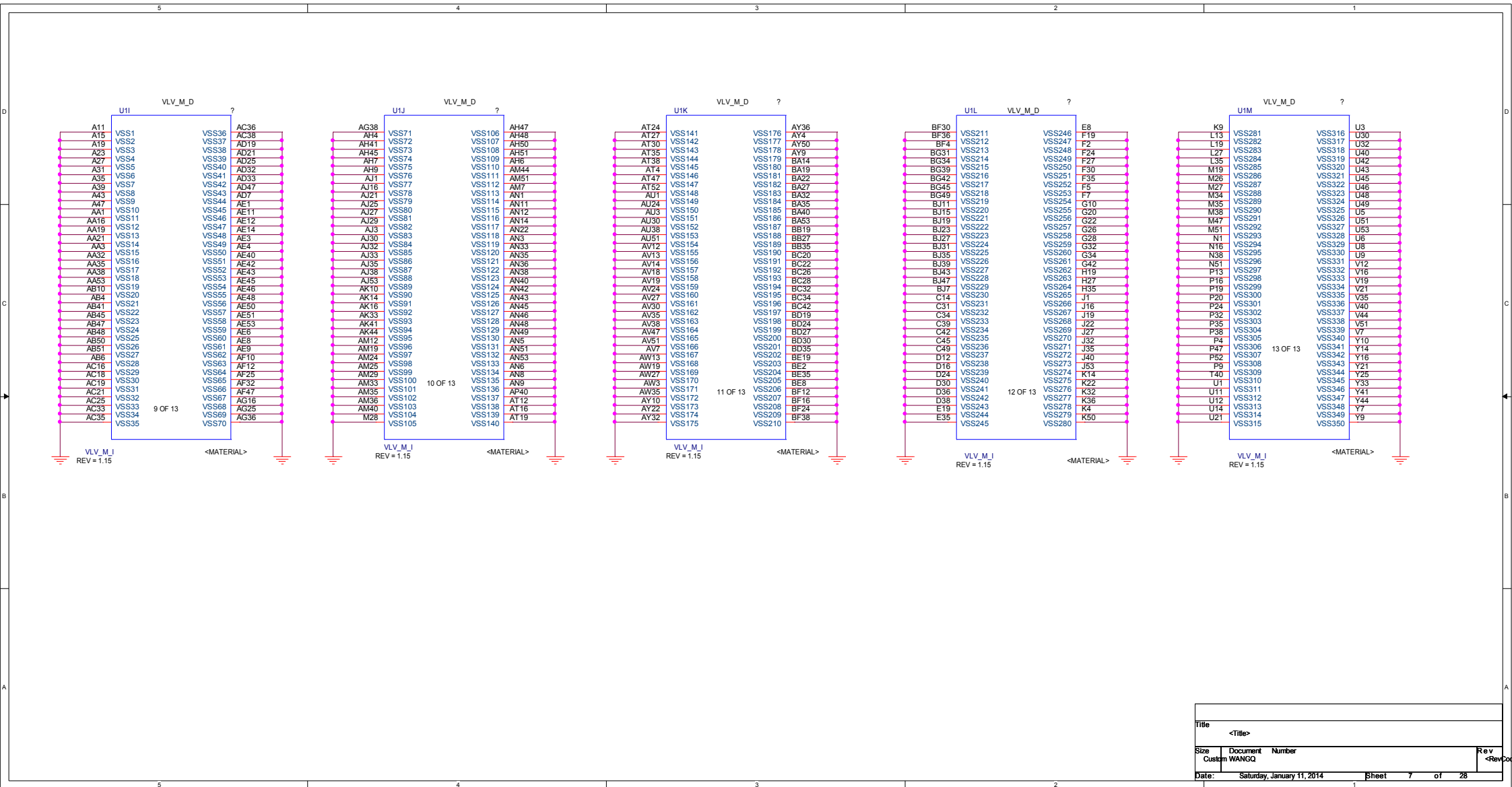

Title	<Title>			Rev	<Rev>
Size	Custom	Document	Number		
Date:	Saturday, January 11, 2014			Sheet	7 of 28

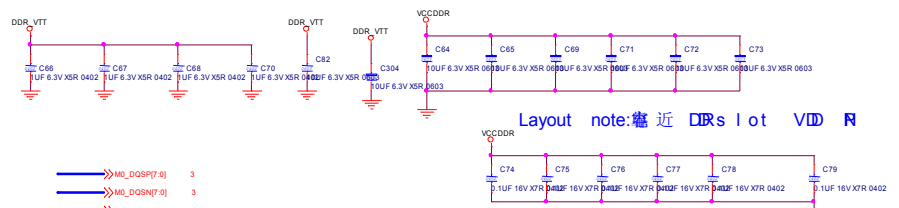

- >>M0_DQSP1[7:0] 3
- >>M0_DQSN1[7:0] 3
- >>M0_DQ[8:3:0] 3
- >>M0_MA[15:0] 3
- >>M0_DM[7:0] 3

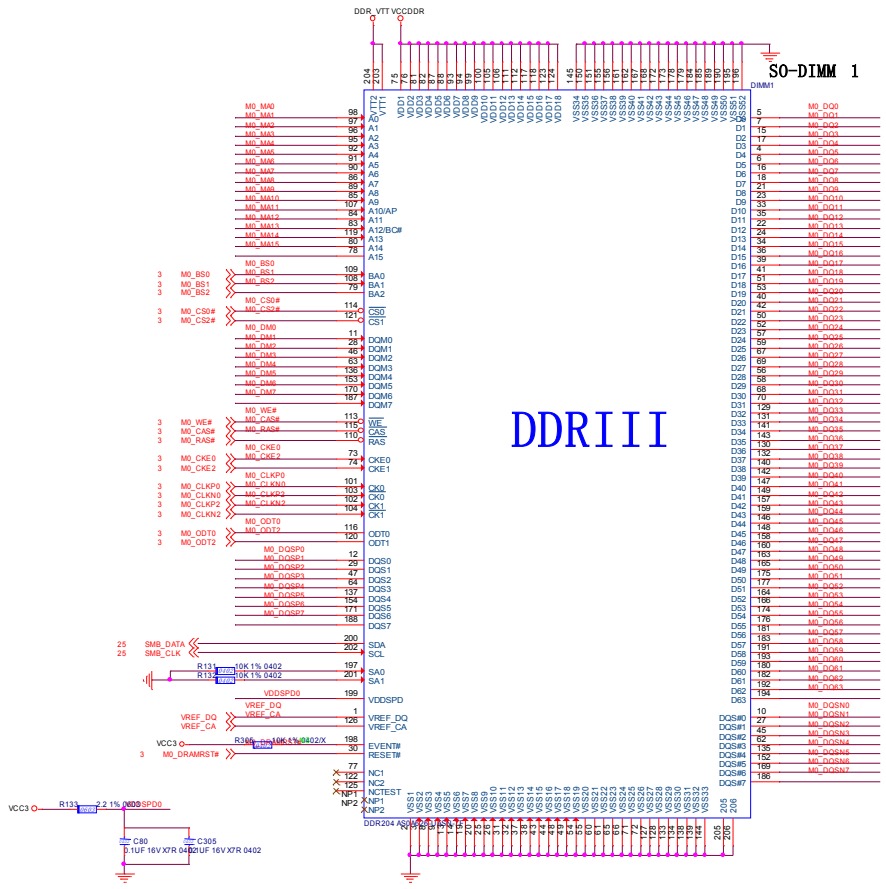
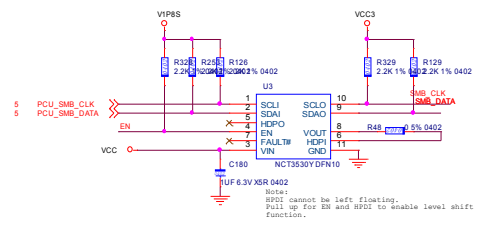

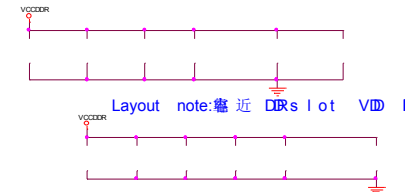
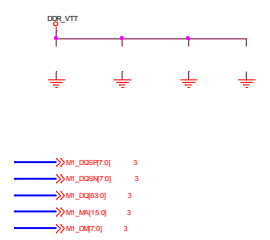

- MI_DQSF1[0] 3
- MI_DQSF1[1] 3
- MI_DQSF1[2] 3
- MI_DM15[0] 3
- MI_DM15[1] 3

		MI_M00		MI_D00
		MI_M01		MI_D01
		MI_M02		MI_D02
		MI_M03		MI_D03
		MI_M04		MI_D04
		MI_M05		MI_D05
		MI_M06		MI_D06
		MI_M07		MI_D07
		MI_M08		MI_D08
		MI_M09		MI_D09
		MI_M10		MI_D10
		MI_M11		MI_D11
		MI_M12		MI_D12
		MI_M13		MI_D13
		MI_M14		MI_D14
		MI_M15		MI_D15
		MI_M16		MI_D16
		MI_M17		MI_D17
		MI_M18		MI_D18
		MI_M19		MI_D19
		MI_M20		MI_D20
		MI_M21		MI_D21
		MI_M22		MI_D22
		MI_M23		MI_D23
		MI_M24		MI_D24
		MI_M25		MI_D25
		MI_M26		MI_D26
		MI_M27		MI_D27
		MI_M28		MI_D28
		MI_M29		MI_D29
		MI_M30		MI_D30
		MI_M31		MI_D31
		MI_M32		MI_D32
		MI_M33		MI_D33
		MI_M34		MI_D34
		MI_M35		MI_D35
		MI_M36		MI_D36
		MI_M37		MI_D37
		MI_M38		MI_D38
		MI_M39		MI_D39
		MI_M40		MI_D40
		MI_M41		MI_D41
		MI_M42		MI_D42
		MI_M43		MI_D43
		MI_M44		MI_D44
		MI_M45		MI_D45
		MI_M46		MI_D46
		MI_M47		MI_D47
		MI_M48		MI_D48
		MI_M49		MI_D49
		MI_M50		MI_D50
		MI_M51		MI_D51
		MI_M52		MI_D52
		MI_M53		MI_D53
		MI_M54		MI_D54
		MI_M55		MI_D55
		MI_M56		MI_D56
		MI_M57		MI_D57
		MI_M58		MI_D58
		MI_M59		MI_D59
		MI_M60		MI_D60
		MI_M61		MI_D61
		MI_M62		MI_D62
		MI_M63		MI_D63
		MI_M64		MI_D64
		MI_M65		MI_D65
		MI_M66		MI_D66
		MI_M67		MI_D67
		MI_M68		MI_D68
		MI_M69		MI_D69
		MI_M70		MI_D70
		MI_M71		MI_D71
		MI_M72		MI_D72
		MI_M73		MI_D73
		MI_M74		MI_D74
		MI_M75		MI_D75
		MI_M76		MI_D76
		MI_M77		MI_D77
		MI_M78		MI_D78
		MI_M79		MI_D79
		MI_M80		MI_D80
		MI_M81		MI_D81
		MI_M82		MI_D82
		MI_M83		MI_D83
		MI_M84		MI_D84
		MI_M85		MI_D85
		MI_M86		MI_D86
		MI_M87		MI_D87
		MI_M88		MI_D88
		MI_M89		MI_D89
		MI_M90		MI_D90
		MI_M91		MI_D91
		MI_M92		MI_D92
		MI_M93		MI_D93
		MI_M94		MI_D94
		MI_M95		MI_D95
		MI_M96		MI_D96
		MI_M97		MI_D97
		MI_M98		MI_D98
		MI_M99		MI_D99
		MI_M100		MI_D100
		MI_M101		MI_D101
		MI_M102		MI_D102
		MI_M103		MI_D103
		MI_M104		MI_D104
		MI_M105		MI_D105
		MI_M106		MI_D106
		MI_M107		MI_D107
		MI_M108		MI_D108
		MI_M109		MI_D109
		MI_M110		MI_D110
		MI_M111		MI_D111
		MI_M112		MI_D112
		MI_M113		MI_D113
		MI_M114		MI_D114
		MI_M115		MI_D115
		MI_M116		MI_D116
		MI_M117		MI_D117
		MI_M118		MI_D118
		MI_M119		MI_D119
		MI_M120		MI_D120
		MI_M121		MI_D121
		MI_M122		MI_D122
		MI_M123		MI_D123
		MI_M124		MI_D124
		MI_M125		MI_D125
		MI_M126		MI_D126
		MI_M127		MI_D127
		MI_M128		MI_D128
		MI_M129		MI_D129
		MI_M130		MI_D130
		MI_M131		MI_D131
		MI_M132		MI_D132
		MI_M133		MI_D133
		MI_M134		MI_D134
		MI_M135		MI_D135
		MI_M136		MI_D136
		MI_M137		MI_D137
		MI_M138		MI_D138
		MI_M139		MI_D139
		MI_M140		MI_D140
		MI_M141		MI_D141
		MI_M142		MI_D142
		MI_M143		MI_D143
		MI_M144		MI_D144
		MI_M145		MI_D145
		MI_M146		MI_D146
		MI_M147		MI_D147
		MI_M148		MI_D148
		MI_M149		MI_D149
		MI_M150		MI_D150
		MI_M151		MI_D151
		MI_M152		MI_D152
		MI_M153		MI_D153
		MI_M154		MI_D154
		MI_M155		MI_D155
		MI_M156		MI_D156
		MI_M157		MI_D157
		MI_M158		MI_D158
		MI_M159		MI_D159
		MI_M160		MI_D160
		MI_M161		MI_D161
		MI_M162		MI_D162
		MI_M163		MI_D163
		MI_M164		MI_D164
		MI_M165		MI_D165
		MI_M166		MI_D166
		MI_M167		MI_D167
		MI_M168		MI_D168
		MI_M169		MI_D169
		MI_M170		MI_D170
		MI_M171		MI_D171
		MI_M172		MI_D172
		MI_M173		MI_D173
		MI_M174		MI_D174
		MI_M175		MI_D175
		MI_M176		MI_D176
		MI_M177		MI_D177
		MI_M178		MI_D178
		MI_M179		MI_D179
		MI_M180		MI_D180
		MI_M181		MI_D181
		MI_M182		MI_D182
		MI_M183		MI_D183
		MI_M184		MI_D184
		MI_M185		MI_D185
		MI_M186		MI_D186
		MI_M187		MI_D187
		MI_M188		MI_D188
		MI_M189		MI_D189
		MI_M190		MI_D190
		MI_M191		MI_D191
		MI_M192		MI_D192
		MI_M193		MI_D193
		MI_M194		MI_D194
		MI_M195		MI_D195
		MI_M196		MI_D196
		MI_M197		MI_D197
		MI_M198		MI_D198
		MI_M199		MI_D199
		MI_M200		MI_D200
		MI_M201		MI_D201
		MI_M202		MI_D202
		MI_M203		MI_D203
		MI_M204		MI_D204
		MI_M205		MI_D205
		MI_M206		MI_D206
		MI_M207		MI_D207
		MI_M208		MI_D208
		MI_M209		MI_D209
		MI_M210		MI_D210
		MI_M211		MI_D211
		MI_M212		MI_D212
		MI_M213		MI_D213
		MI_M214		MI_D214
		MI_M215		MI_D215
		MI_M216		MI_D216
		MI_M217		MI_D217
		MI_M218		MI_D218
		MI_M219		MI_D219
		MI_M220		MI_D220
		MI_M221		MI_D221
		MI_M222		MI_D222
		MI_M223		MI_D223
		MI_M224		MI_D224
		MI_M225		MI_D225
		MI_M226		MI_D226
		MI_M227		MI_D227
		MI_M228		MI_D228
		MI_M229		MI_D229
		MI_M230		MI_D230
		MI_M231		MI_D231
		MI_M232		MI_D232
		MI_M233		MI_D233
		MI_M234		MI_D234
		MI_M235		MI_D235
		MI_M236		MI_D236
		MI_M237		MI_D237
		MI_M238		MI_D238
		MI_M239		MI_D239
		MI_M240		MI_D240
		MI_M241		MI_D241
		MI_M242		MI_D242
		MI_M243		MI_D243
		MI_M244		MI_D244
		MI_M245		MI_D245
		MI_M246		MI_D246
		MI_M247		MI_D247
		MI_M248		MI_D248
		MI_M249		MI_D249
		MI_M250		MI_D250
		MI_M251		MI_D251
		MI_M252		MI_D252
		MI_M253		MI_D253
		MI_M254		MI_D254
		MI_M255		MI_D255
		MI_M256		MI_D256
		MI_M257		MI_D257
		MI_M258		MI_D258
		MI_M259		MI_D259
		MI_M260		MI_D260
		MI_M261		MI_D261
		MI_M262		MI_D262
		MI_M263		MI_D263
		MI_M264		MI_D264
		MI_M265		MI_D265
		MI_M266		MI_D266
		MI_M267		MI_D267
		MI_M268		MI_D268
		MI_M269		MI_D269
		MI_M270		MI_D270
		MI_M271		MI_D271
		MI_M272		MI_D272
		MI_M273		MI_D273
		MI_M274		MI_D274
		MI_M275		MI_D275
		MI_M276		MI_D276
		MI_M277		MI_D277
		MI_M278		MI_D278
		MI_M279		MI_D279
		MI_M280		MI_D280
		MI_M281		MI_D281
		MI_M282		MI_D282
		MI_M283		MI_D283
		MI_M284		MI_D284
		MI_M285		MI_D285
		MI_M286		MI_D286
		MI_M287		MI_D287
		MI_M288		MI_D288
		MI_M289		MI_D289
		MI_M290		MI_D290
		MI_M291		MI_D291
		MI_M292		MI_D292
		MI_M293		MI_D293
		MI_M294		MI_D294
		MI_M295		MI_D295
		MI_M296		MI_D296
		MI_M297		MI_D297
		MI_M298		MI_D298
		MI_M299		MI_D299
		MI_M300		MI_D300

DDR I I

LEVEL SHIFT

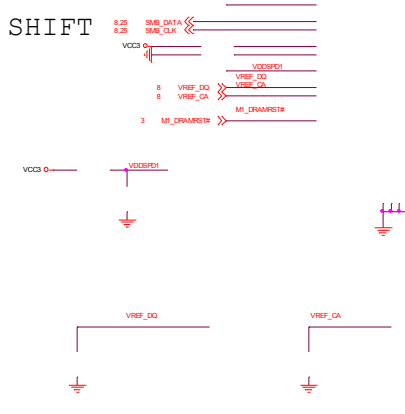

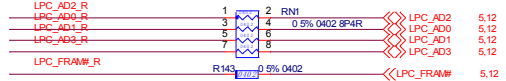

MINI-PCIE V1.2 SPEC;

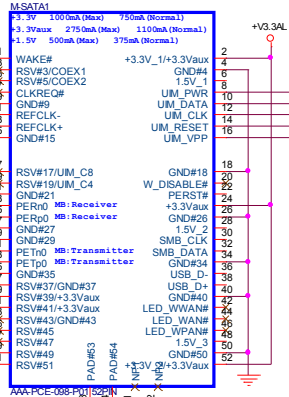

P N CHANGE FOR MSATA

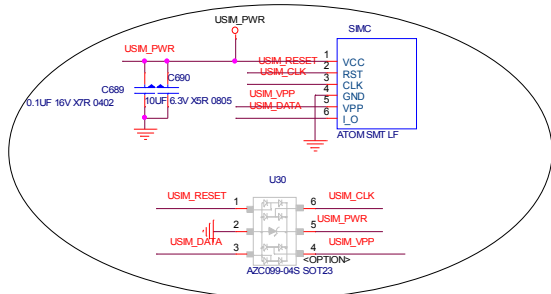
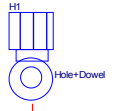
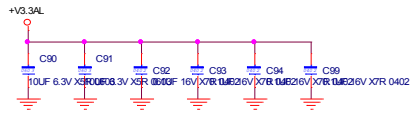
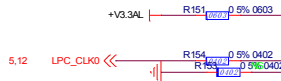
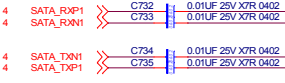

MINI-PCIE V1.2 SPEC;

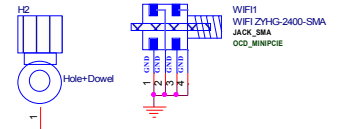
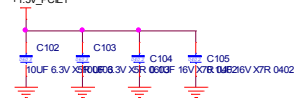
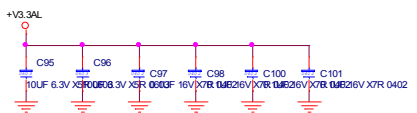
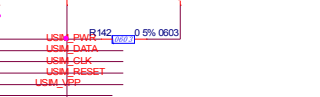
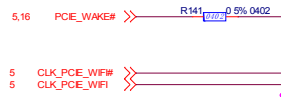
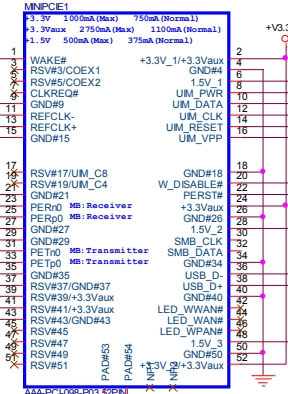

Title	<Title>
Size	Custom
Document	WANG3Q
Number	
Date:	Saturday, January 11, 2014
Sheet	10 of 28

SATA CONNECTOR

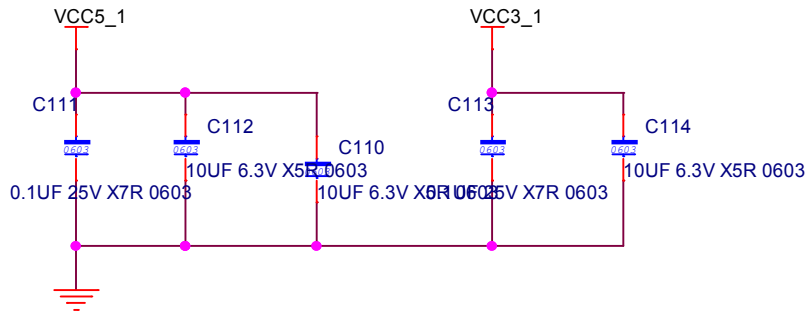
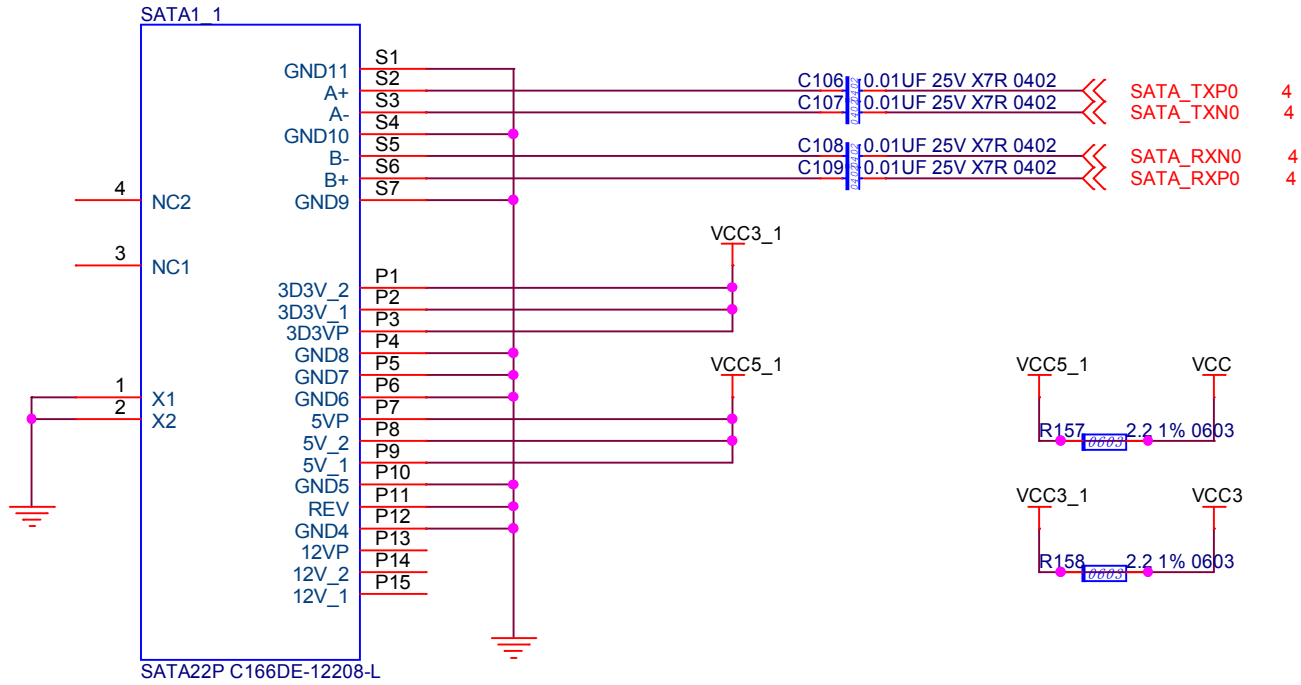

Title			<Title>
Size	Document	Number	Rev
A	WANGQ		<RevCode>
Date:	Saturday, January 11, 2014	Sheet	11 of 28

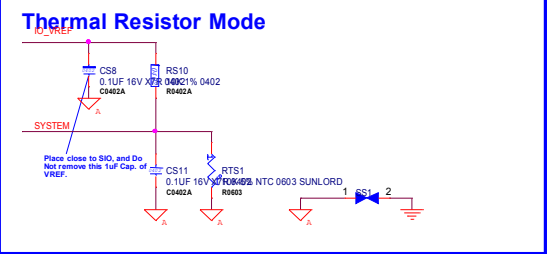
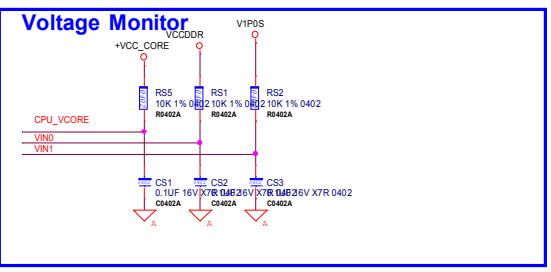
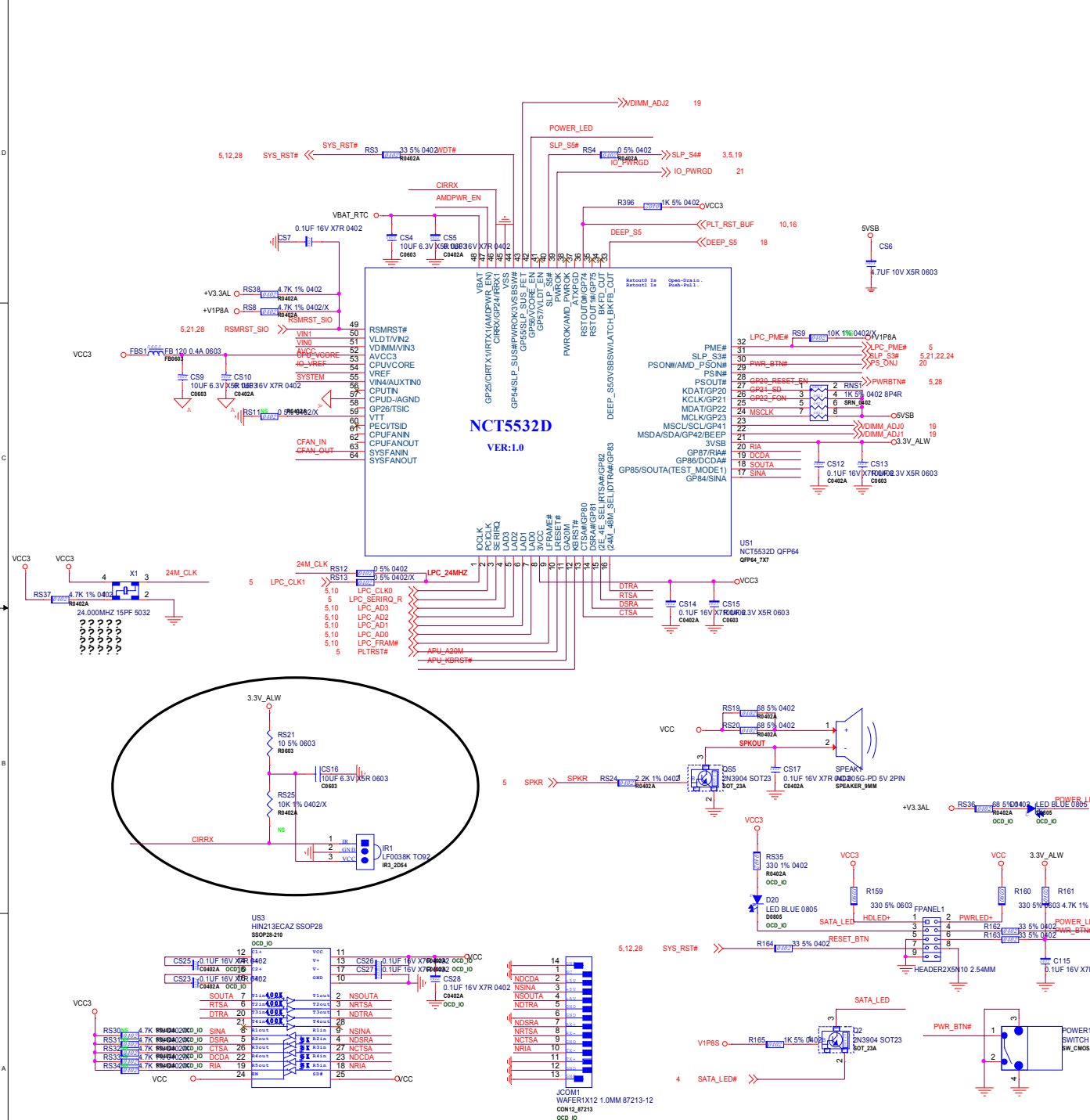

Power On Strapping

PIN15/RTSA	2E_4E_SEL	Strapped by LRESET#	1 4Eh/4Fh 0 2Eh/2Fh
PIN16/DTRA	24M_48M_SEL	Strapped by VCC	1 48MHz 0 24MHz
PIN18/SOUTA	TEST_MODE1	Strapped by VCC	strapped to low
PIN47	AMDPWR_EN	Strapped by VSB	1 Enable 0 Disable

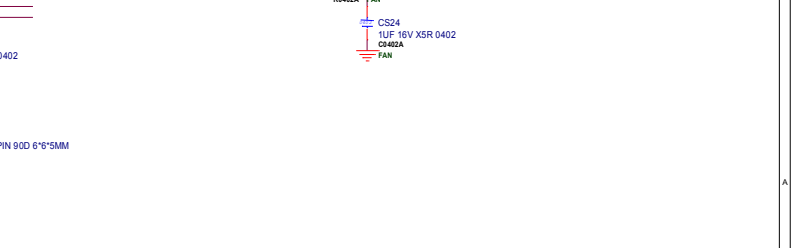
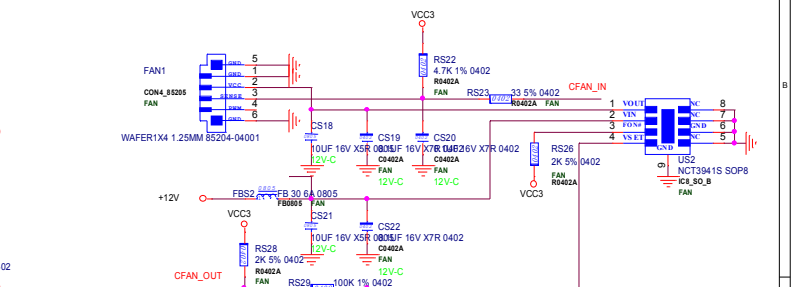
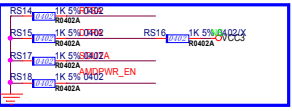

Title	<Title>
Size	Document Number
Author	WANGQ
Date	Saturday, January 11, 2014
Sheet	12 of 28

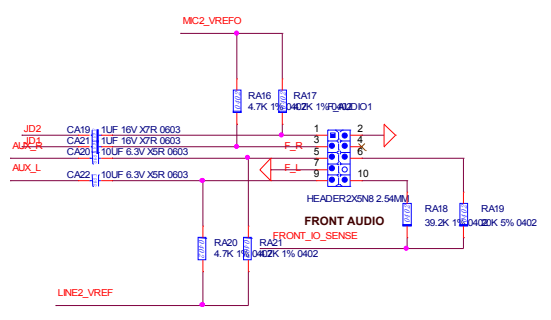
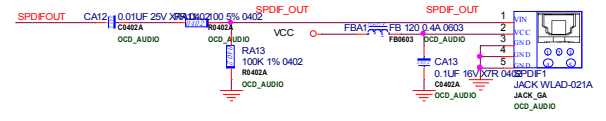
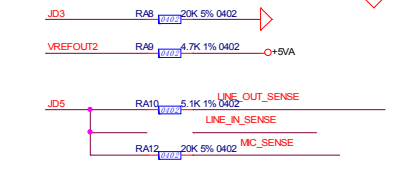
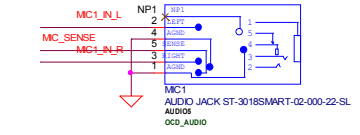
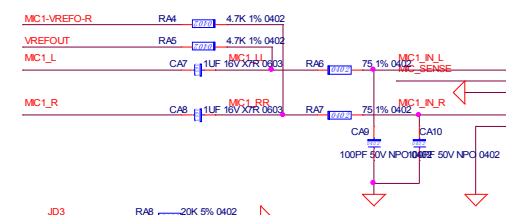
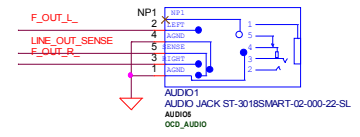
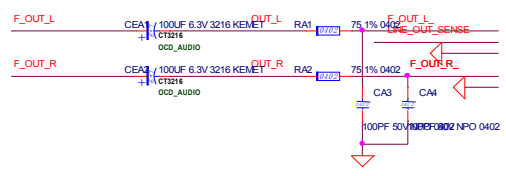
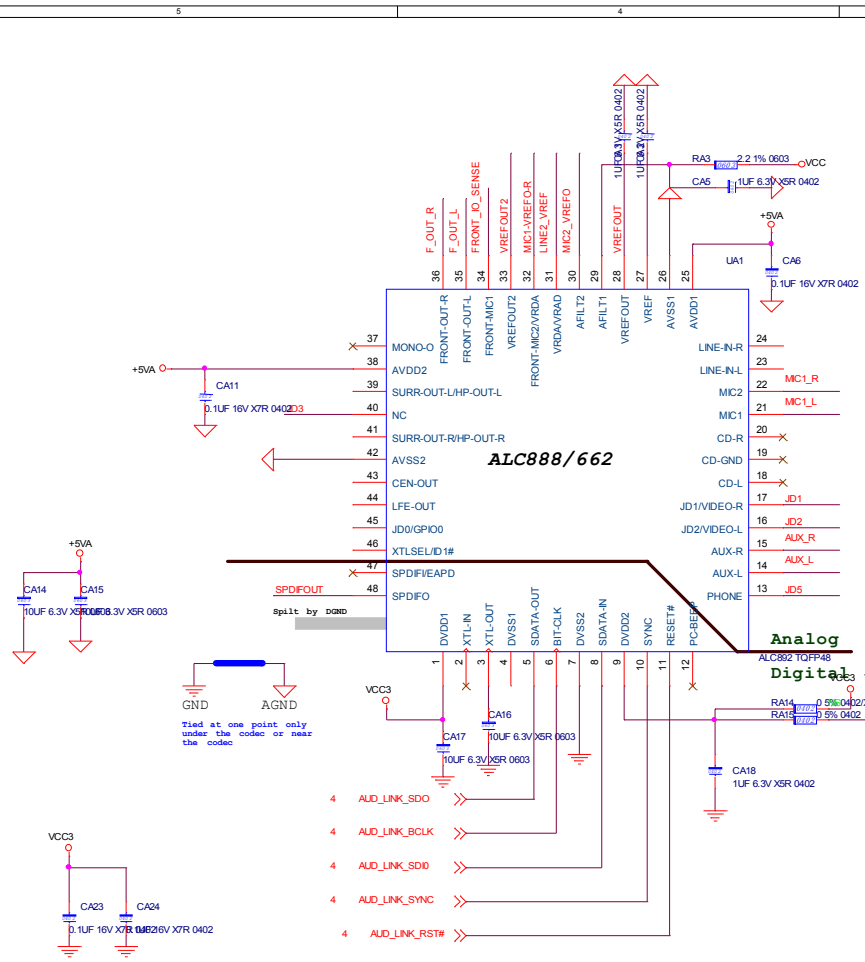

Title	<Title>	Rev	<Rev>
Size	Document Number	Sheet	13 of 28
Date	Saturday, January 11, 2014	Sheet	13 of 28

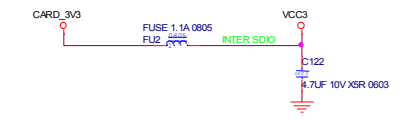
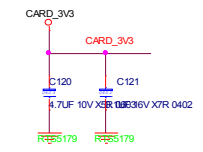
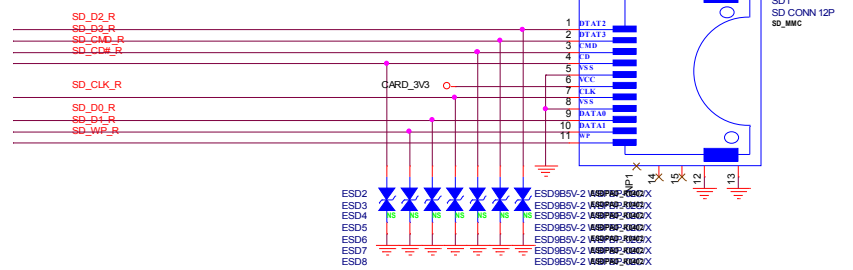
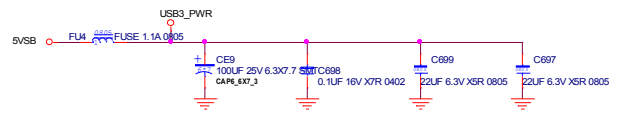
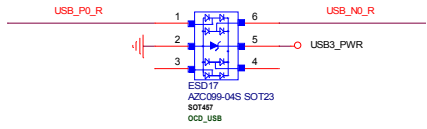
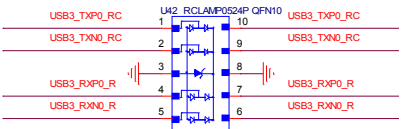
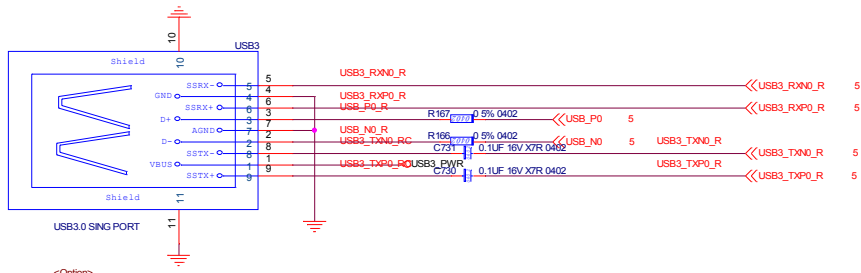

File	<Title>			Rev
Size	Document	Number		<Rev Code>
Custom	WANGSQ			
Date:	Saturday, January 11, 2014	Sheet	14 of 28	

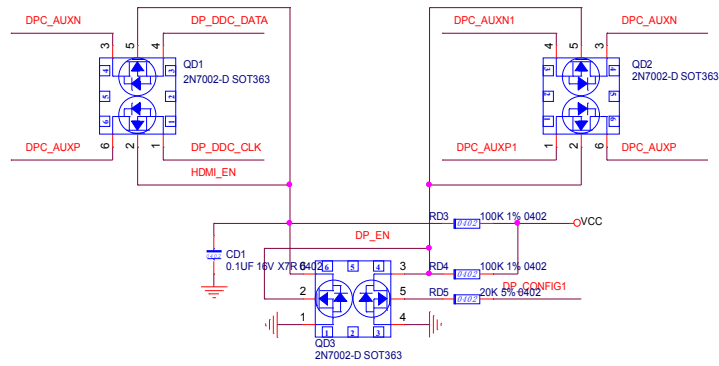
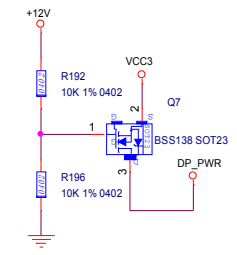
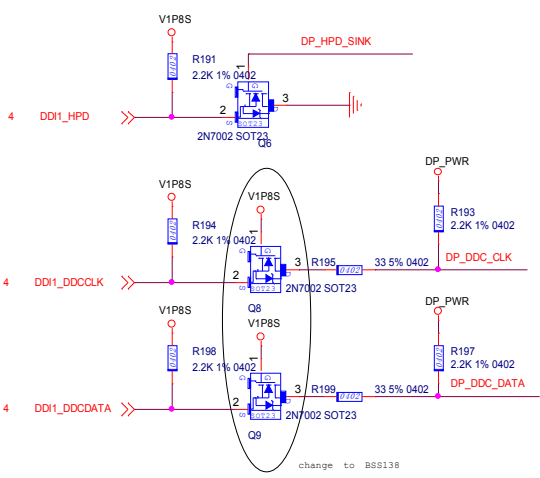
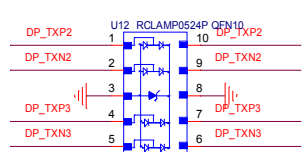
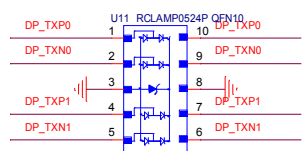
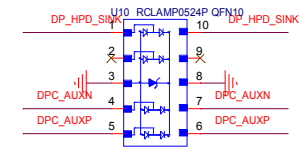
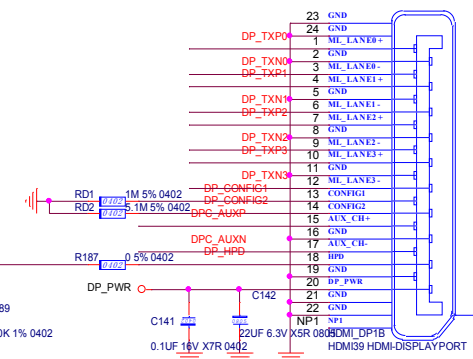
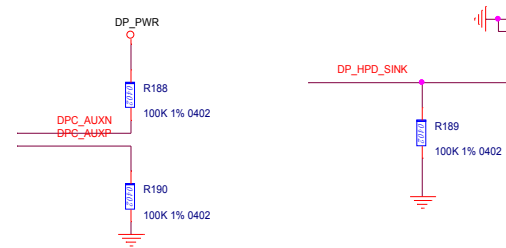
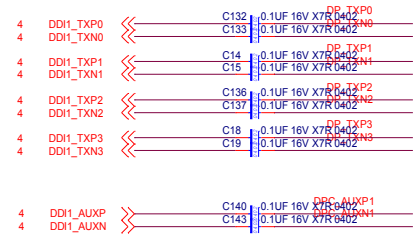
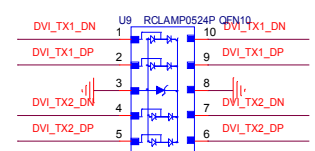
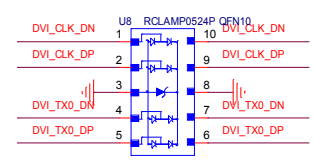
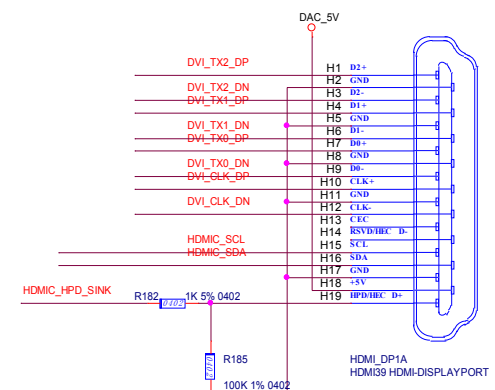
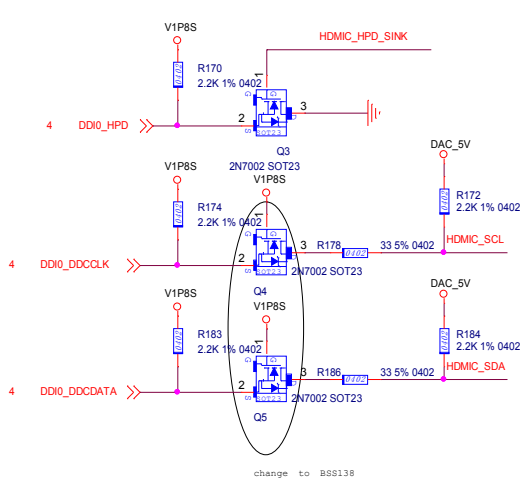
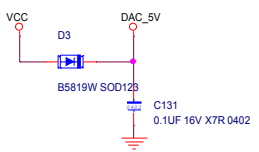
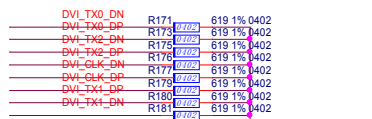
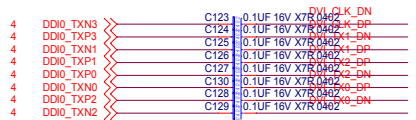

Title	<Title>			Rev
Size	Document	Number		
Date:	Custom	WANGC	<Rev>	
Date:	Wednesday, January 22, 2014	Sheet	15	of 28

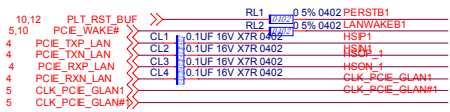

Function (EEPROM, Efuses, ASF)

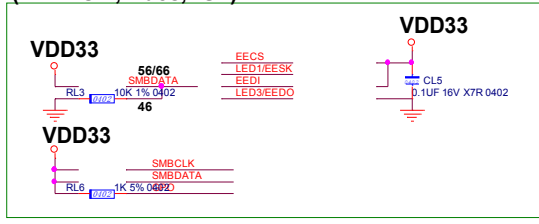

Pin44-XTAL2 is External Clock Input Pin. R38 is needed when using external clock source.

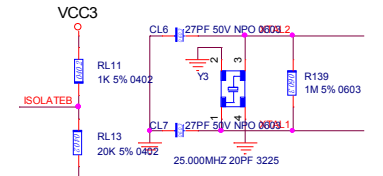
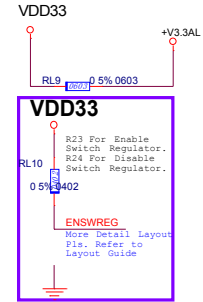
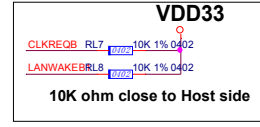
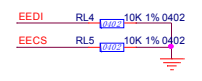

For RTL8111B-VB
* C12 to C17 are for VDD33 pins-- 12, 27, 39, 42, 47, 48.

For RTL8105E-VB
* C12 to C16 are for VDD33 pins-- 27, 39, 42, 47, 48.

For RTL8105E-VC
* C12 to C15 are for VDD33 pins-- 27, 39, 47, 48.

For RTL8111B-VB
* C1 to C7 are for VDD10 pins-- 3, 6, 9, 13, 29, 41, 45.

For RTL8105E-VB
* C1 to C4 are for VDD10 pins-- 3, 13, 29, 45.

For RTL8105E-VC
* C1 to C3 are for VDD10 pins-- 13, 29, 45.

External 1.05V Supply When Not Using Switch Regulator. If Using External 1.2V Supply Pls. Contact With P&E.

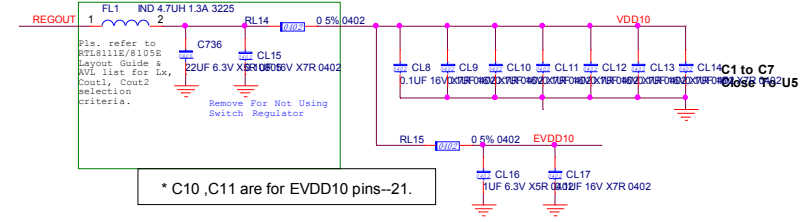

* C10, C11 are for EVDD10 pins--21.

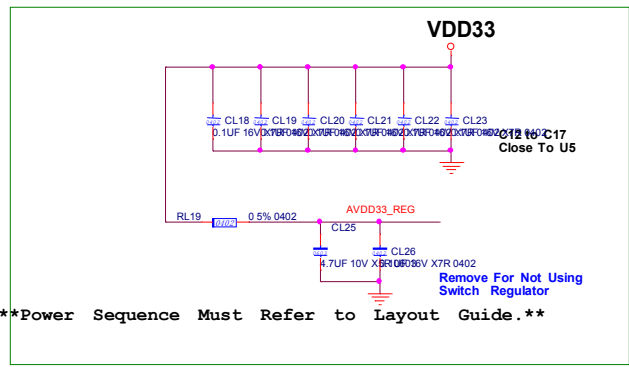
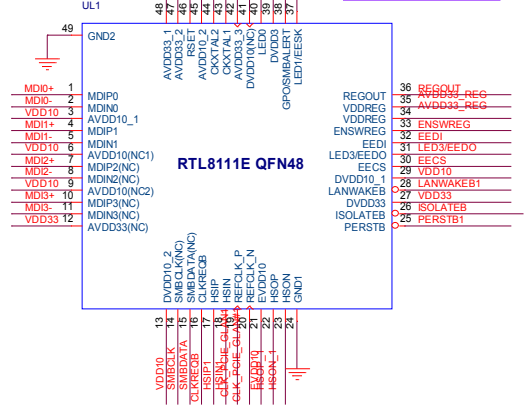
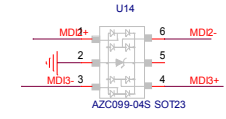
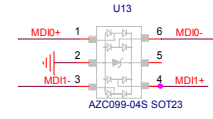

Power Sequence Must Refer to Layout Guide.

C10, C11 Close To U5 Pin 21.	mode	Lx	Cout1,2	R1	Cin1,2	R3	R23	R24
8111E-VB/8105E-VB/8105E-VC	SWR	O	O	O	O	O	O	X
8105E-VC	LDO	X	X	X	X	X	X	O
8111E-VB/8105E-VB	External	X	X	X	X	X	X	O
8105E-VC	External	X	X	X	X	X	O	X

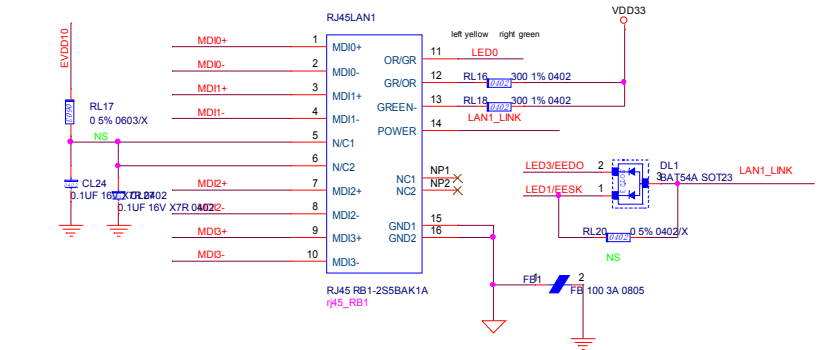

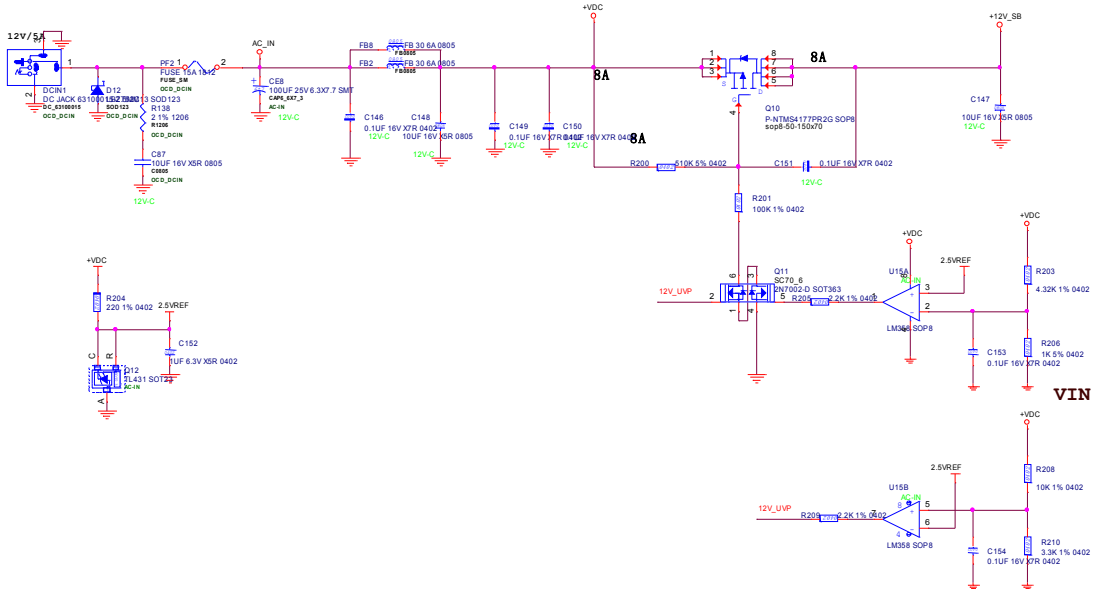

VIN MAX 13.2V
 MIN 10.2V

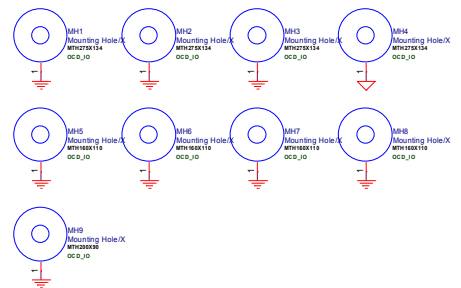

File	DC IN		
Size	Document Number	Rev	0
	Cuspm	WANGQ	
Date:	Saturday, January 11, 2014	Sheet	17 of 28

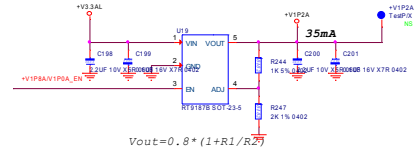
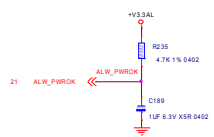
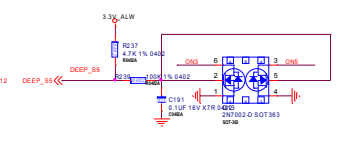
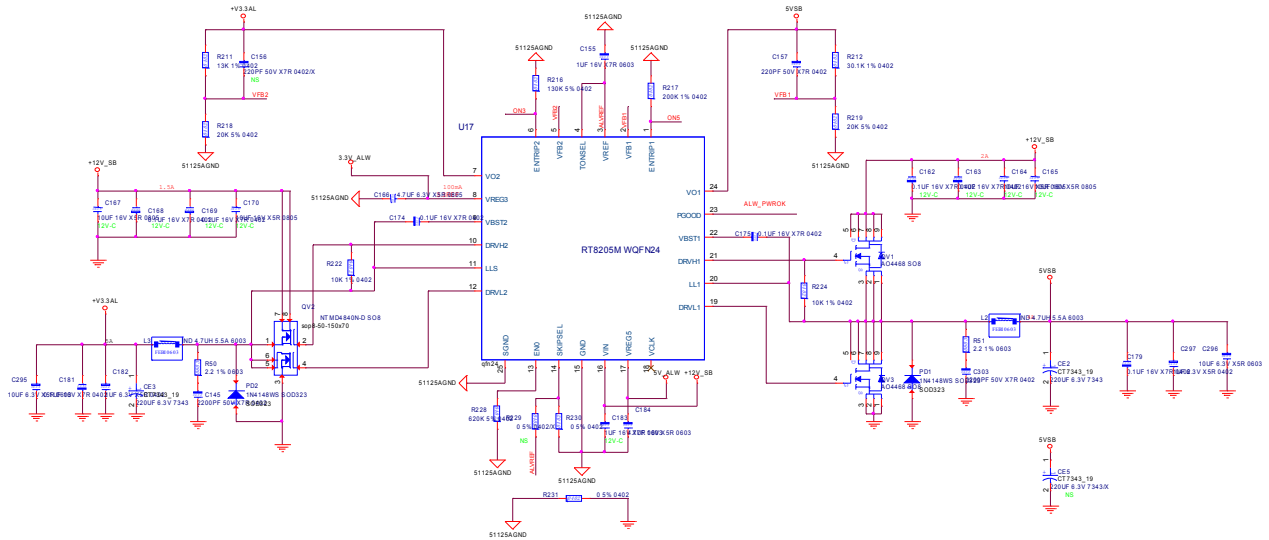

$$V_{out} = 0.8 * (1 + R1/R2)$$

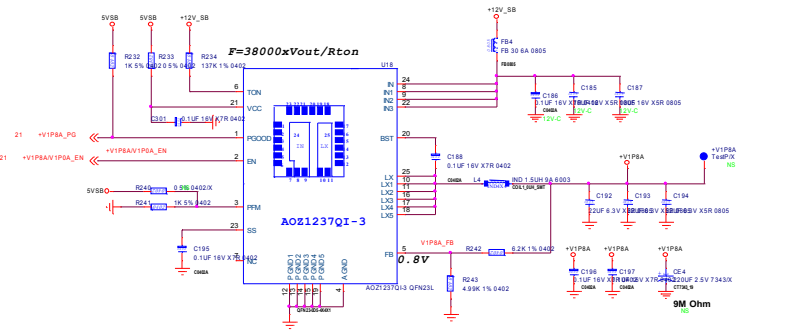
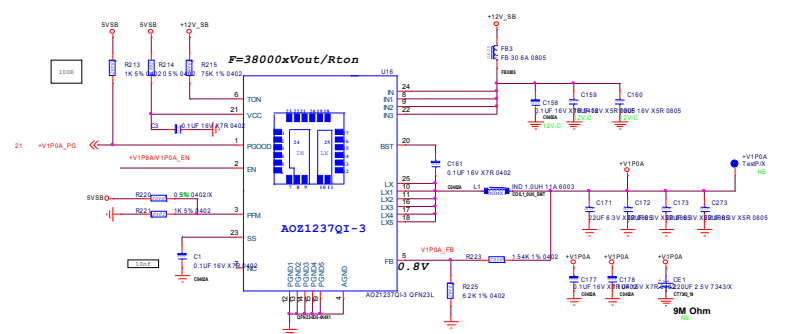

Rev	<Title>	Rev	<Docu>
001	Document Number	001	<Rev>
001	Docu#WQFN24	001	<Rev>
001	Rev. 1	001	<Rev>

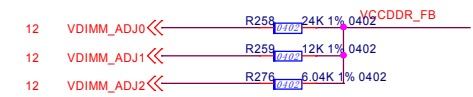
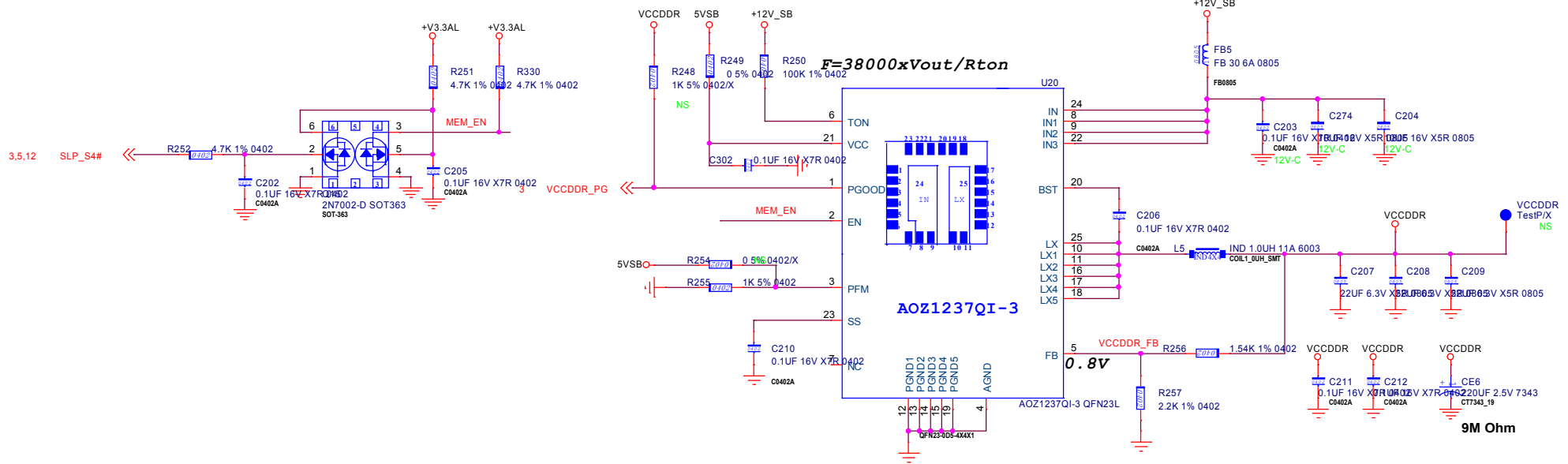

1.36---1.71v

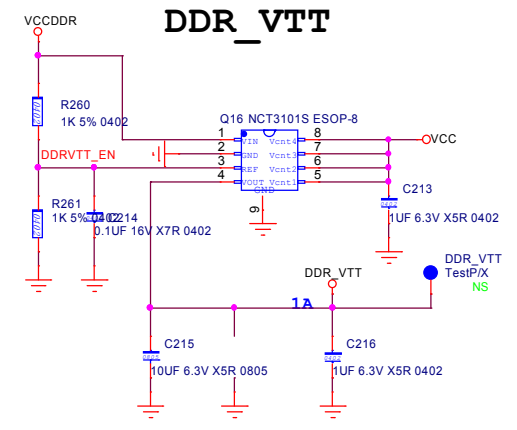

Title			
<Title>			
Size	Document	Number	Rev
Custom	WANGQ		<Rev Code>
Date:	Saturday, January 11, 2014	Sheet	19 of 28

5VSB 0 mA
 +V3.3AL 0 mA
 +V1P8A 0 mA
 +V1P2A 0 mA
 +V1P0A 0 mA
 8 mA V1P8S
 54.87 mA V1P8S
 7.20 mA V1P3SS
 105.6 mA V1P3SS
 V1P8S
 V1P3SS

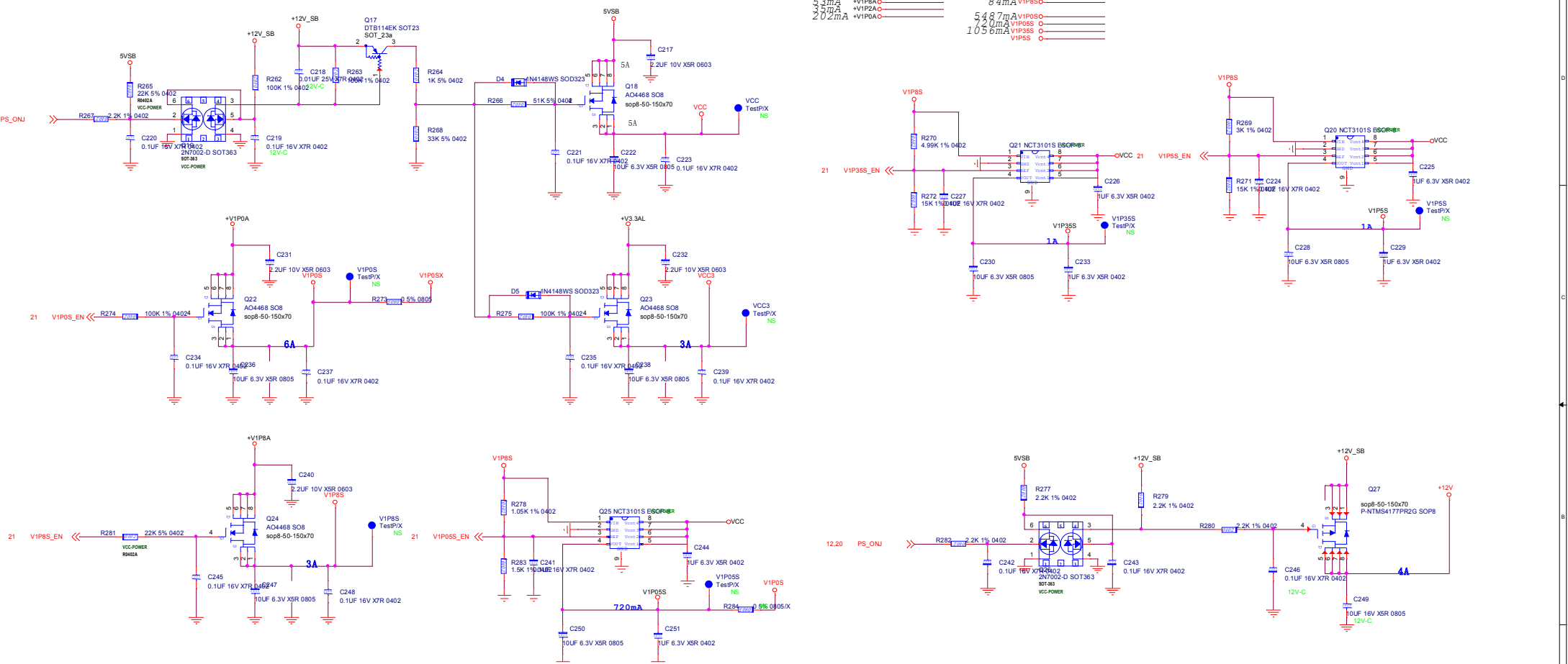

Title			
<Title>			
Size	Document	Number	Rev
Custom	WANGQ		<Rev Code>
Date:	Saturday, January 11, 2014	Sheet	20 of 28

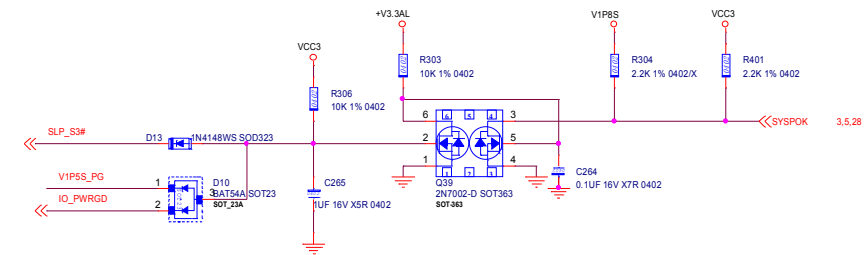
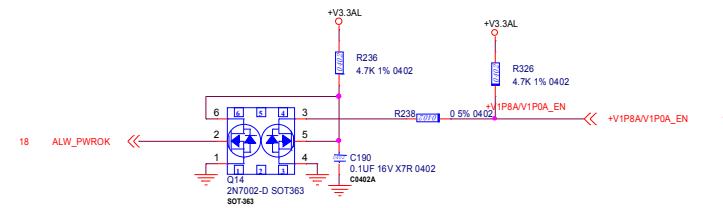
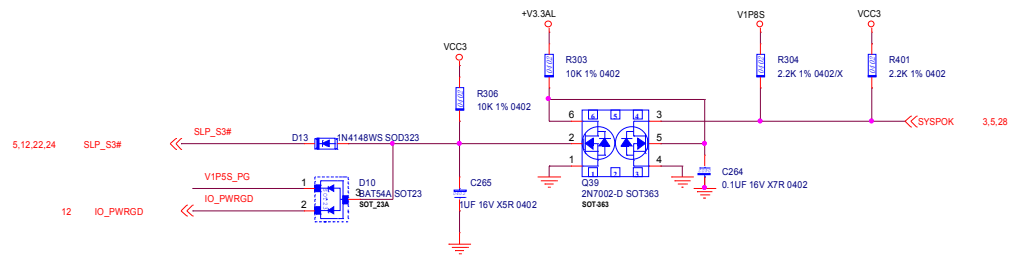
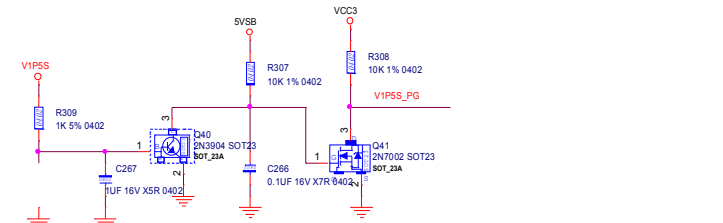
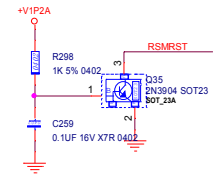
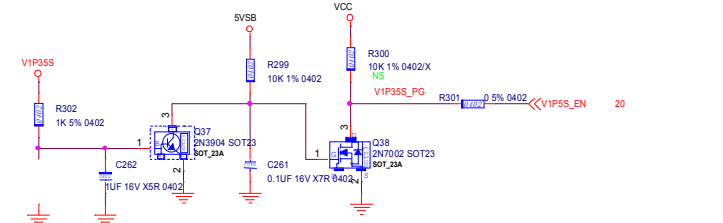
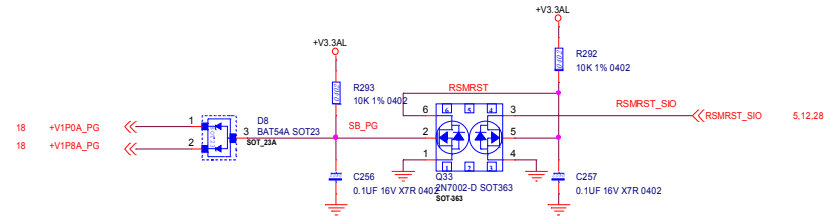
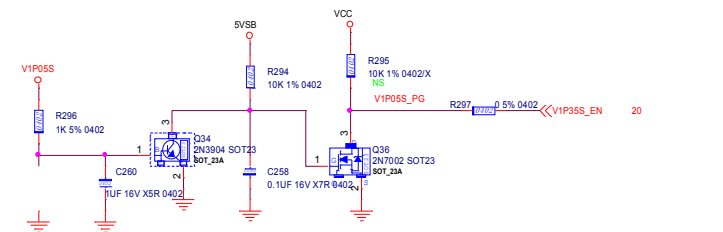
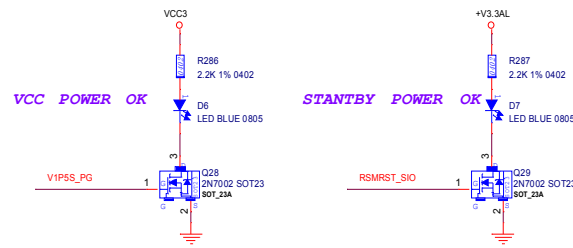
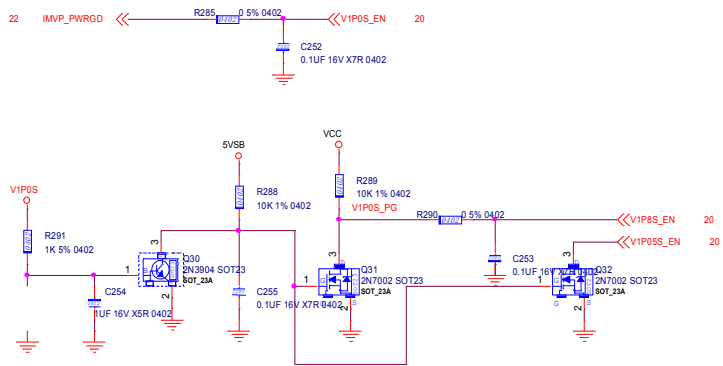

Title	<Title>		
Size	Document	Number	Rev
Custom	WANGQ		<Rev>
Date:	Saturday, January 11, 2014	Sheet 21	of 28

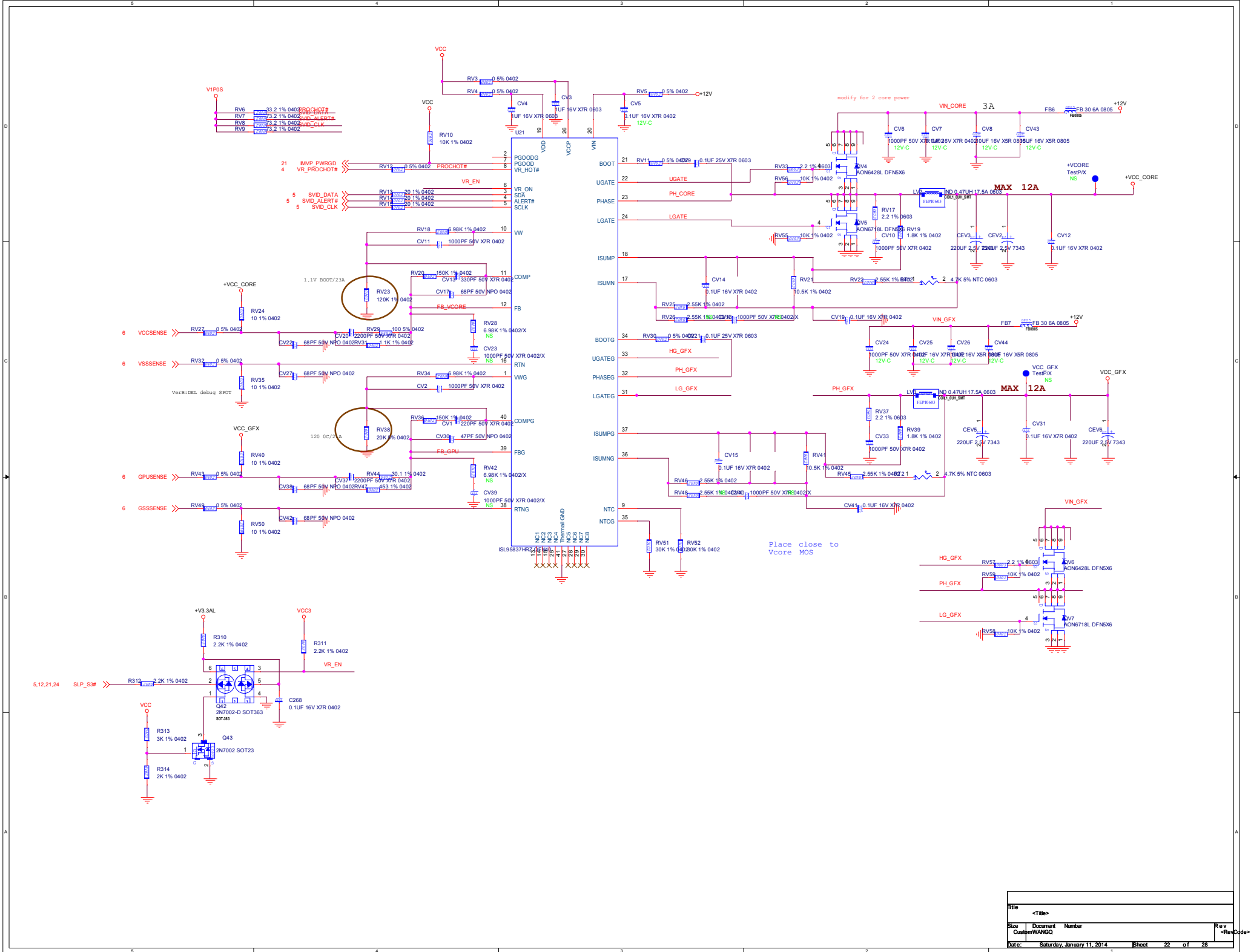

Title				<Title>
Size	Document	Number	Rev	
Cusum	WANGQ		<Rev Code>	
Date:	Saturday, January 11, 2014	Sheet	22	of 28



D

D

C

C

B

B

A

A

5

4

3

2

1

5

4

3

2

1

Title			
<Title>			
Size	Document	Number	Rev
Custom	WANGG		<Rev>
Date:		Saturday, January 11, 2014	Sheet 23 of 28

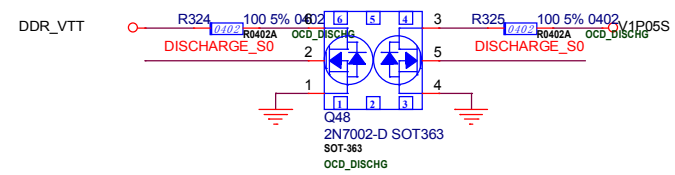
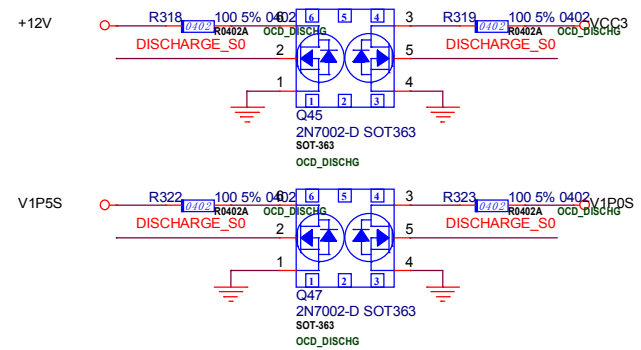
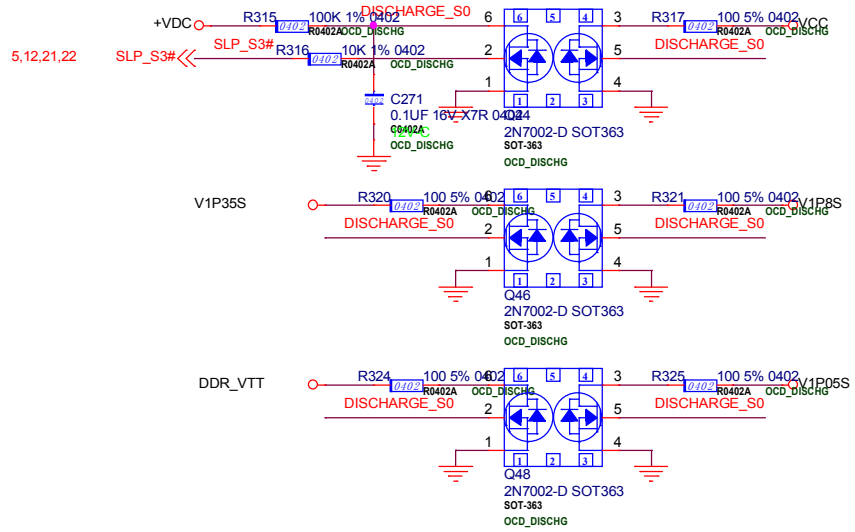

Title			<Title>
Size	Document	Number	Rev
Custom	WANGQ		<RevCo
Date:	Saturday, January 11, 2014	Sheet	24 of 28

XDP

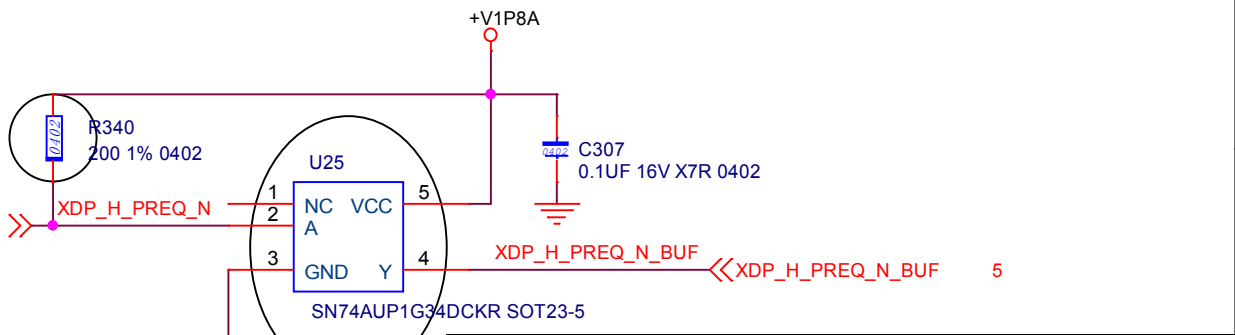
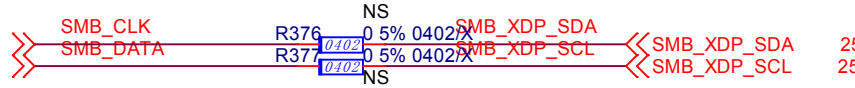
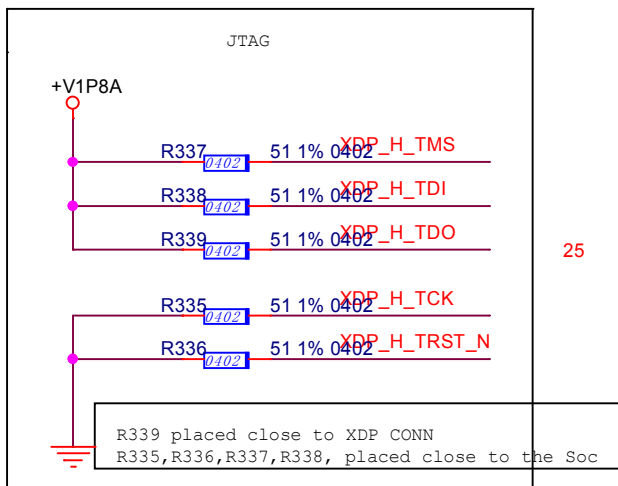
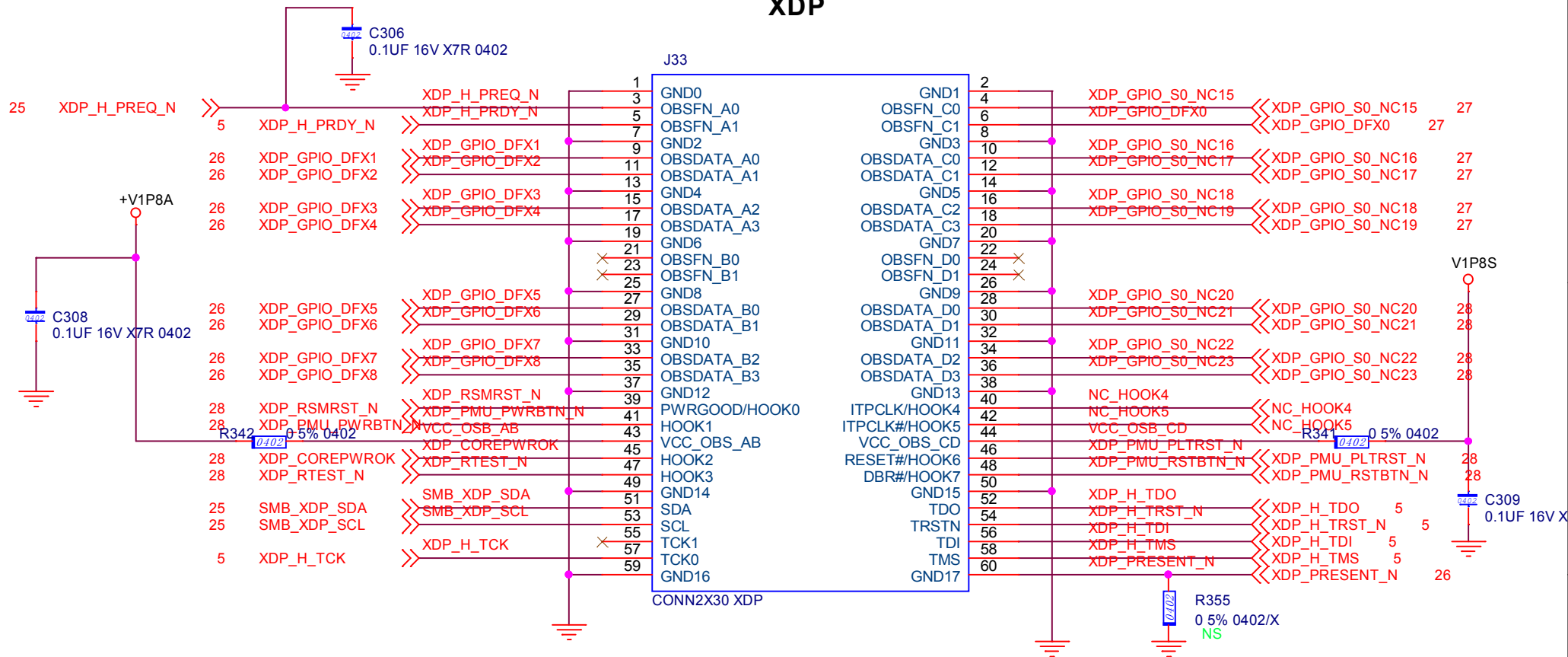

R339 placed close to XDP CONN
R335, R336, R337, R338, placed close to the Soc

Title			<Title>
Size	Document Number	Rev	
A	<Doc>	<RevCode>	
Date:	Saturday, January 11, 2014	Sheet	25 of 28

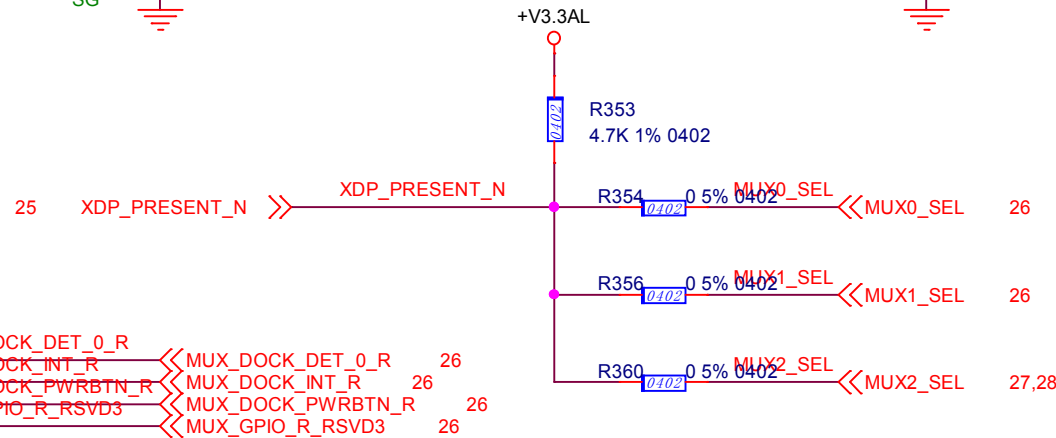
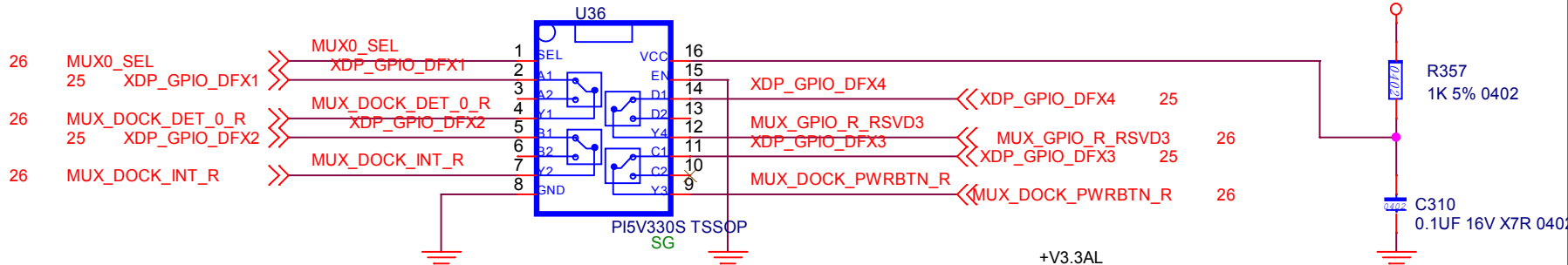

Title			<Title>
Size	Document Number	Rev	
A	<Doc>	<RevCode>	
Date:	Saturday, January 11, 2014	Sheet	26 of 28

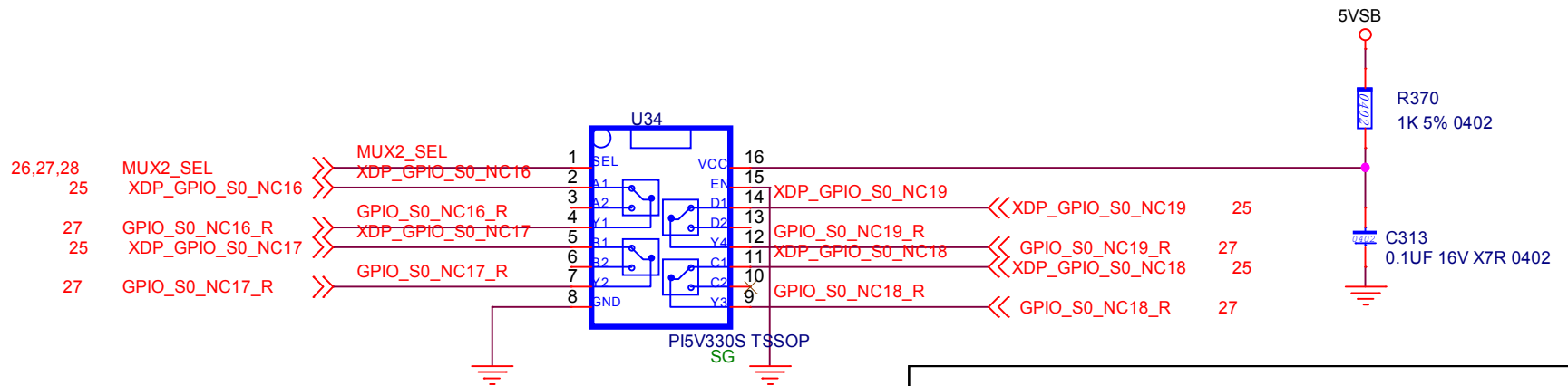
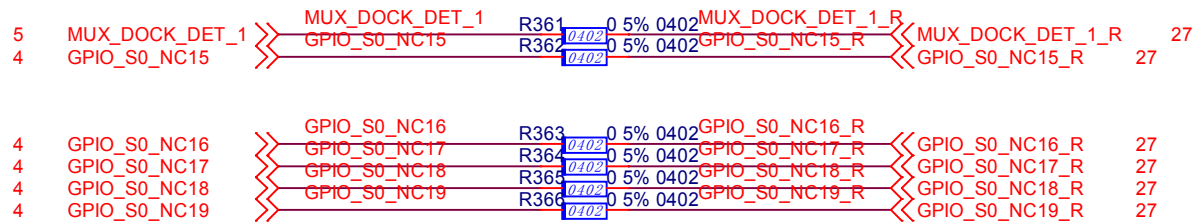
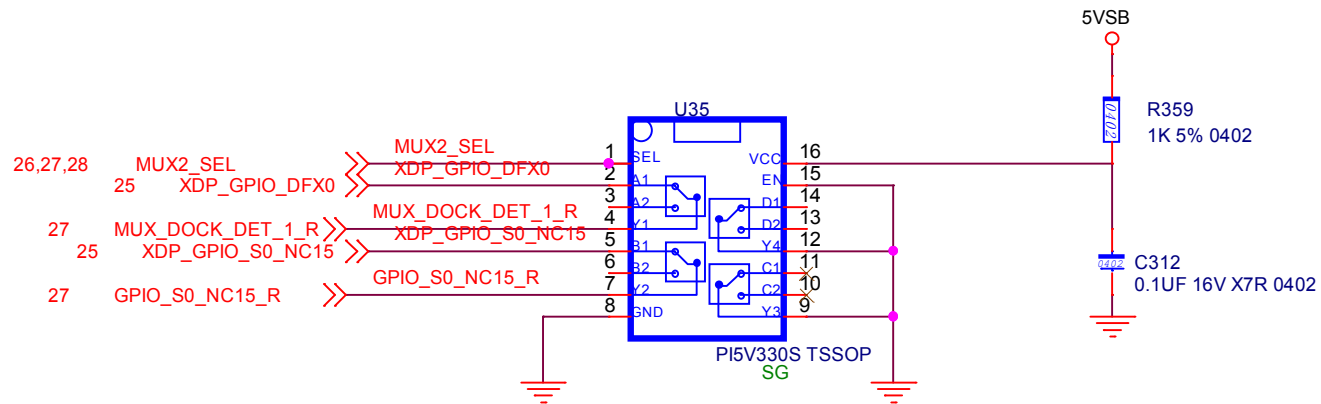

Title			<Title>
Size	Document Number	Rev	
A	<Doc>	<RevCode>	
Date:	Saturday, January 11, 2014	Sheet	27 of 28

4	GPIO_S0_NC20	GPIO_S0_NC20	R372	0 5% 0402	GPIO_S0_NC20_R	28
4	GPIO_S0_NC21	GPIO_S0_NC21	R371	0 5% 0402	GPIO_S0_NC21_R	28
4	GPIO_S0_NC22	GPIO_S0_NC22	R373	0 5% 0402	GPIO_S0_NC22_R	28
4	GPIO_S0_NC23	GPIO_S0_NC23	R374	0 5% 0402	GPIO_S0_NC23_R	28

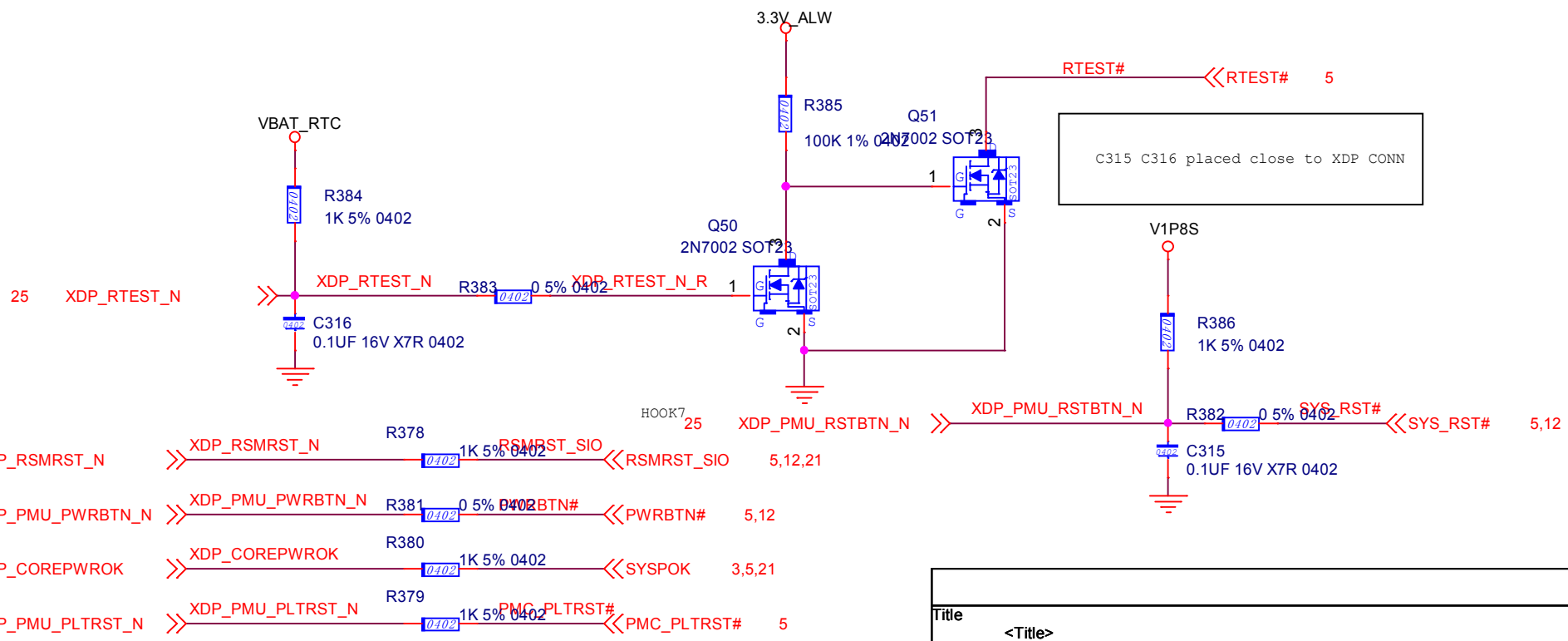
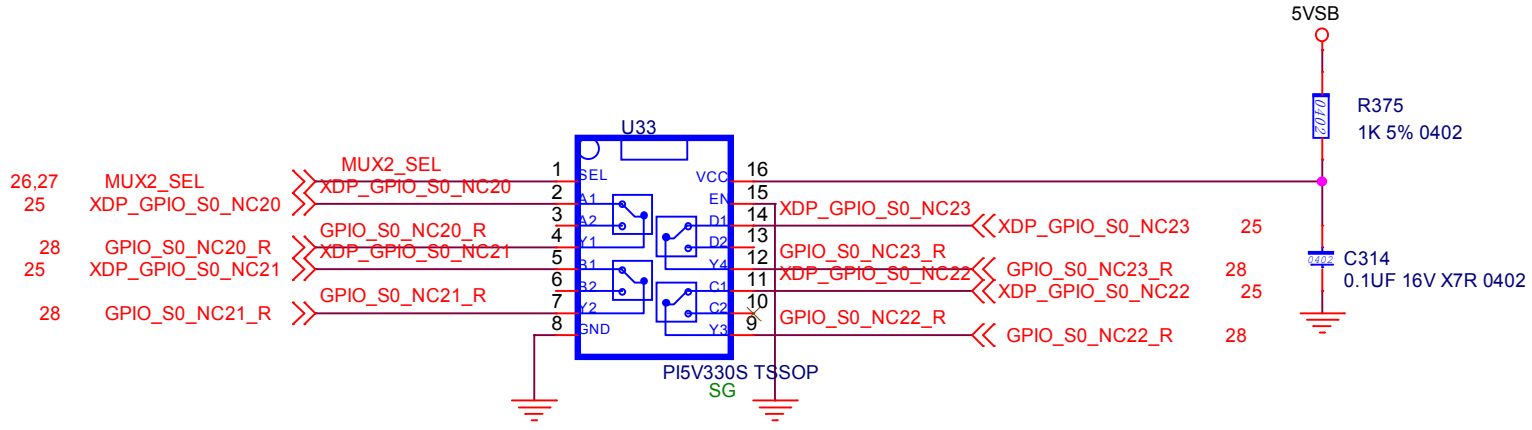

Title			<Title>
Size	Document	Number	Rev
A	<Doc>		<RevCode>
Date:	Saturday, January 11, 2014	Sheet	28 of 28